

Dump Trailer



300 Series Dump Trailer

- Available in 10 – 20 tonne carrying capacities
- Patented tail- door design enables the Dump Trailer to be used with or without the tail-door in operation, without the need for hydraulics
- Side panels manufactured from 5mm thick steel and supported by a continuous horizontal bulge bar to ensure excellent strength to weight ratio
- Body pivot hinge designed to ensure maximum height of discharge. Higher pivot point for easy stockpiling
- Wider and lower construction for better stability and ease of loading with rubber tyred or mini track excavators
- Body can be scraped clean using 6ft (1.8m) bucket



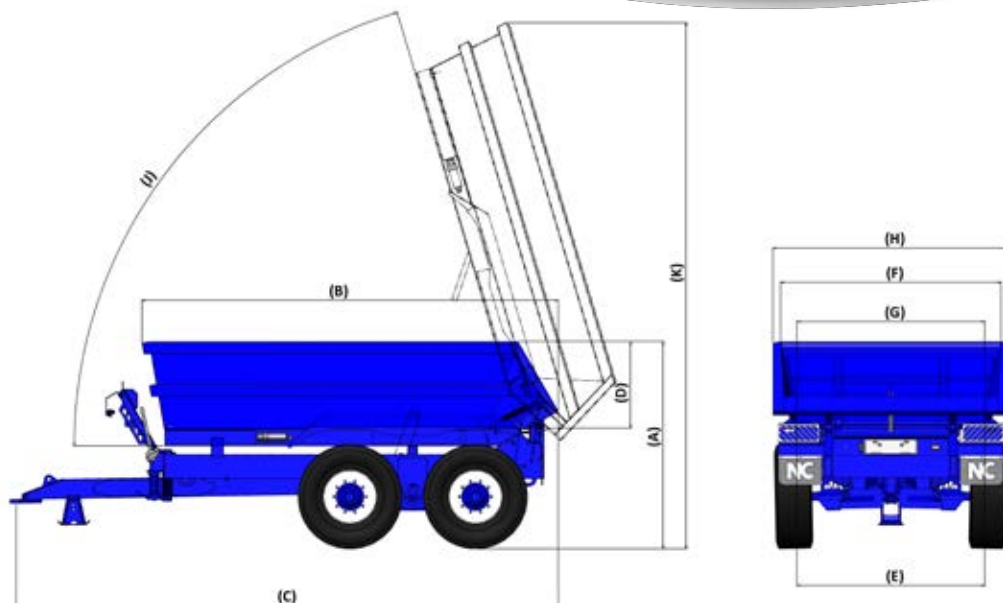

300 Series										
	Units	310 (10T)	312 (12T)	314 (14T)	316 (16T)	318 (18T)	320 (20T)	320 On 560/60 R22.5	320 On 650/55x26.5	320 On 710/50x26.5 (Narrow Chassis)
Overall Height (A)	m	1.98	2.08	2.15	2.22	2.32	2.38	2.38	2.38	2.38
Body Length (B)	m	3.87	4.19	4.34	4.38	4.76	4.78	4.78	4.78	4.78
Overall Length (C)	m	5.10	5.40	5.54	5.54	5.94	5.94	5.94	5.94	5.94
Floor to top of side (D)	m	0.67	0.74	0.82	0.92	0.92	1.02	1.02	1.02	1.02
Width of floor (E)	m	1.83	2.00	2.00	2.00	2.00	2.00	2.00	2.00	2.00
Inside body width at top side (F)	m	2.06	2.26	2.28	2.32	2.32	2.36	2.36	2.36	2.36
Inside body width at bottom side (G)	m	1.83	2.00	2.00	2.00	2.00	2.00	2.00	2.00	2.00
Overall width (H)	m	2.34	2.46	2.46	2.46	2.50	2.54	2.54	2.54	2.54
Tipping Angle (J)	°	77	73	73	73	72.5	72.5	72.5	72.5	72.5
Max height when tipped (K)	m	5.12	5.45	5.49	5.58	6.00	6.00	6.00	6.00	6.00
Number of axles	Qty	2	2	2	2	2	2	2	2	2
Floor Thickness	mm	8.00	8.00	8.00	8.00	8.00	8.00	8.00	8.00	8.00
Wall Thickness	mm	5.00	5.00	5.00	5.00	5.00	5.00	5.00	5.00	5.00
Volume	m ³	4.30	5.70	6.30	7.20	8.00	9.00	9.00	9.00	9.00
Draw Bar	Type	Sprung	Sprung	Sprung	Sprung	Sprung	Sprung	Sprung	Sprung	Sprung
Axles	Type	80mm 8 Stud	80mm 8 Stud	90mm 10 Stud	100mm 10 Stud	127mm 10 Stud	127mm 10 Stud	120mm 10 Stud	120mm 10 Stud	120mm 10 Stud
Hydraulic Brakes	Type	350x60	350x60	400x80	400x80	420x180	420x180	420x180	420x180	420x180
Slack Adjusters	Type	Yes	Yes	Yes	Yes	Yes	Yes	Yes	Yes	Yes
Tyres	Type	385x65 x22.5	385x65 x22.5	385x65 x22.5	385x65 x22.5	445x65 x22.5	445x65 x22.5	560/60 x22.5	650/55 x26.5	710/50 x26.5

- Available in 12 – 16 tonne carrying capacities
- Hydraulic rear door, folding flat to floor
- Side panels manufactured from 5mm thick steel and supported by a continuous horizontal bulge bar to ensure excellent strength to weight ratio
- Option of 4 metre aluminium ramps with maximum carrying capacity of 6950 kgs
- Storage trays for aluminium ramps integrated into the chassis
- 4 floor hooks inside body for securing loads for safe transportation (eg Mini Digger)
- 5mm Hardox Floor



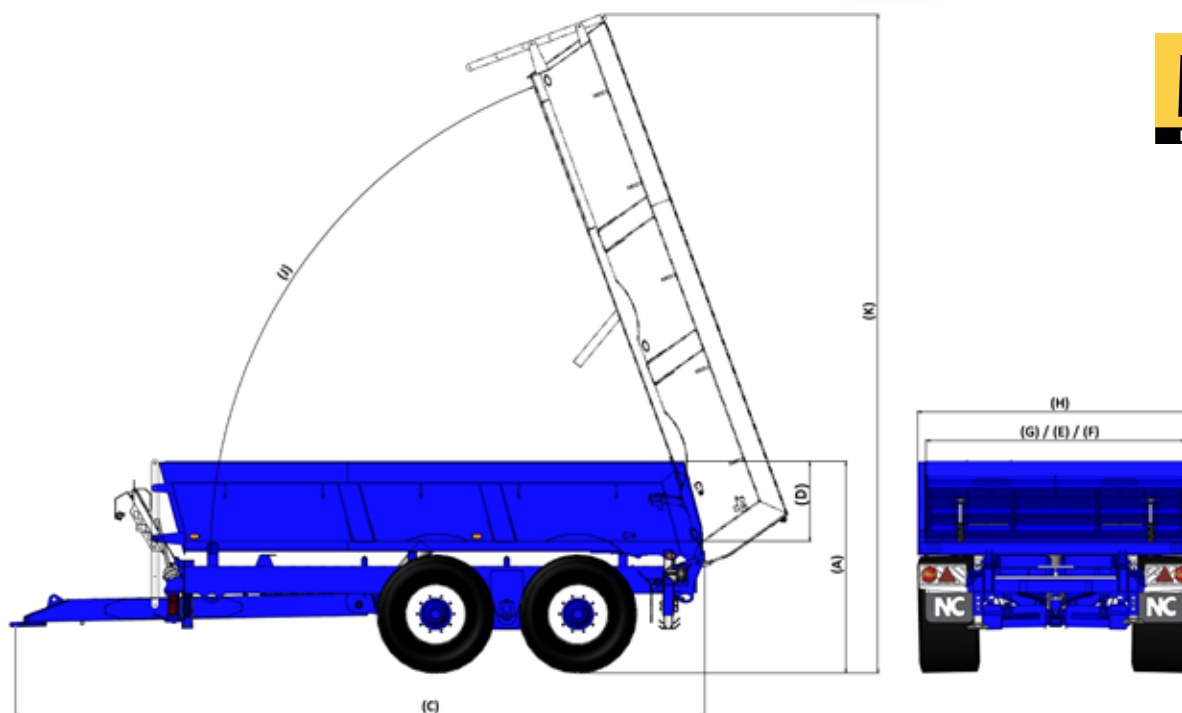

600 Series				
	Units	612 (12T)	614 (14T)	616 (16T)
Overall Height (A)	m	1.93	2.00	2.08
Body Length (B)	m	5.00	5.00	5.00
Overall Length (C)	m	6.34	6.34	6.34
Floor to top of side (D)	m	0.57	0.64	0.72
Width of floor (E)	m	2.40	2.40	2.40
Inside body width at top side (F)	m	2.40	2.40	2.40
Inside body width at bottom side (G)	m	2.40	2.40	2.40
Overall width (H)	m	2.54	2.54	2.54
Tipping Angle (J)	°	72	72	72
Max height when tipped (K)	m	6.10	6.10	6.10
Number of axles	Qty	2	2	2
Floor Thickness	mm	5.00	5.00	5.00
Wall Thickness	mm	5.00	5.00	5.00
Volume	m ³	5.70	6.40	7.20
Draw Bar	Type	Sprung	Sprung	Sprung
Axles	Type	80mm 8 Stud	90mm 10 Stud	100mm 10 Stud
Hydraulic Brakes	Type	350x60	400x80	400x80
Slack Adjusters	Type	Yes	Yes	Yes
Tyres	Type	385x65x22.5	385x65x22.5	385x65x22.5

- Available in 8 - 15 tonne carrying capacities
- Twin tail door system with top hinged inner door and bottom hinged hydraulic door
- Top door can be removed when transporting bulky loads eg tree stumps
- Wider and lower construction for better stability and ease of loading with rubber tyred or mini track excavators
- Floor width up to 2.38 metres to allow scraping with bucket of digger or transportation of mini excavators



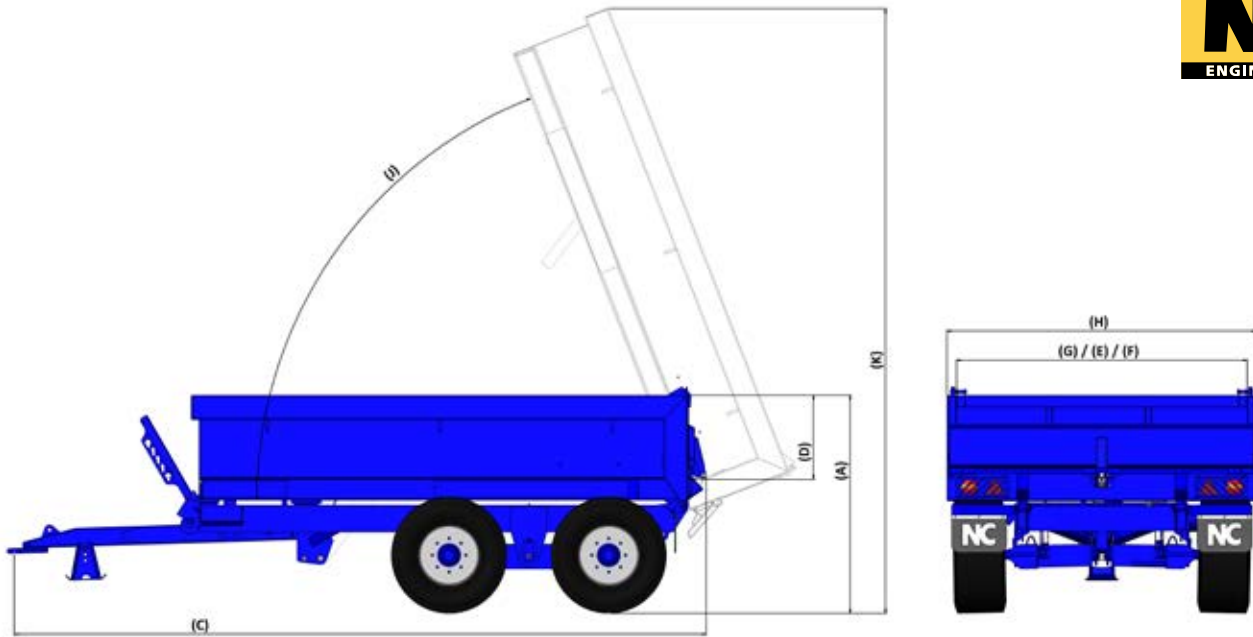

Euro Series				
	Units	8T	12T	15T
Overall Height (A)	m	1.62	1.93	2.00
Body Length (B)	m	4.10	4.10	4.10
Overall Length (C)	m	5.70	5.70	5.70
Floor to top of side (D)	m	0.41	0.67	0.74
Width of floor (E)	m	2.35	2.40	2.40
Inside body width at top side (F)	m	2.35	2.40	2.40
Inside body width at bottom side (G)	m	2.35	2.40	2.40
Overall width (H)	m	2.48	2.54	2.54
Tipping Angle (J)	°	69.6	67.8	68.1
Max height when tipped (K)	m	4.85	5.00	5.00
Number of axles	Qty	2	2	2
Floor Thickness	mm	6 (S355)	8 (S355)	8 (Hardox)
Wall Thickness	mm	5 (S355)	5 (S355)	5 (Hardox)
Volume	m ³	4.30	5.30	10.20
Draw Bar	Type	Fixed	Sprung	Sprung
Axles	Type	70mm 6 Stud	80mm 8 Stud	127mm 10 Stud
Hydraulic Brakes	Type	300x60	350x60	420x180
Slack Adjusters	Type	No	Yes	Yes
Tyres	Type	400x60x15.5	425x55x19.	560x60x22.5



LED Lights and Galvanised Guards



Ratchet Park Brake



Sprung Drawbar Complete with Galvanised Parking Stand



Body Safety Prop



**Weight Transfer System (Standard on 18 & 20 Tonne only –
Option on 10 - 16 Tonne)**



Magic Tail Door

Options



Hardox Body



Adjustable Hitch



Hydraulic Brakeaway



Weld on Stone Guard



Galvanised Bolt on Stone Guard



Hydraulic Jack



Front to Rear Cover



**Galvanised Ladder
(300 Series)**



Swivel Hitch



Galvanised Extension Sides



Air & Hydraulic Brakes or Air Only Brakes



Galvanised Mudguards



Optional Extras

Optional Extras (Euro series only)

8 Tonne Drop Side (one side only)
8 Tonne Swing Drawbar
Hydraulic folding side
Top hinge door only - manual latches
Top hinge door only c/w side hinging & storage bracket
Two Way Tip
Removable Rear Bale Rack

Optional Extras (All Dump Trailers)

10 Stud Axles on 12 Tonne
420 x 180 High Speed Axles
Rear Steering axle (18 and 20 tonne)
Tandem axle on sprung bogie or tandem spring complete with adjustable hitch (12 – 16 tonne)
10mm floor
12mm floor
6mm hardox floor in lieu of standard
8mm hardox floor in lieu of standard
6mm sides
8mm sides
Hardox body, 6mm floor, 4mm sides, 6mm door
Hardox body, like for like

TYRES

445/65 R22.5
560/45 R22.5
560/60 R22.5
Other options available on request

BRAKES

Dual Air/Hydraulic brakes
Air only brakes
Hydraulic brakes load sensing - only available on trailers with suspension

Air brakes load sensing – only available on trailers with suspension
Powerbrake
Cable operated breakaway system
Trailer to ROI standard c/w cable operated system
NC Electric operated breakaway system
12v ABS complete with Susie
24v ABS complete with Susie
Autoslack Adjusters

Other

Steel toolbox
Plastic toolbox
Weld on stone guard
Bolt on stone guard
Weight transfer Rams
Adjustable Hitch
Swivel Hitch
Weld-on spoon type K80 in lieu of standard
Bolt-on spoon type K80 in lieu of standard
Bolt-on 50mm agri in lieu of standard
Rear Tow Hitch c/w Light socket
Folding Rear Tow Hitch c/w Light Socket
Hydraulic Jack
Long vehicle signs (legal requirement for tractor & trailer 13m + in ROI)
Flashing beacon
L.E.D. Control Kit
Side marker lights
Reversing Camera
Dual tail lights (Two rear clusters positioned side-by-side)
LED flasher (2 loose wires for customer to connect to tractor)
Side and Rear Reflective Tape
Screw Jack (commercial type)

Revision 2 – November 2018

In accordance with our policy of continued development we reserve the right to alter specification and design without notice.



NC Engineering (Hamiltonsbawn) Ltd
2 Killyrudden Road
Hamiltonsbawn
Co. Armagh
Northern Ireland
BT61 9SF

Tel: 028 38 871970
Fax: 028 38 870362

www.nc-engineering.com

