

# Wheel Loaders

## G+ SERIES

521G+ | 621G+ | 651G+  
721G+ | 821G+ | 921G+



**CASE**  
CONSTRUCTION

# G+ WHEEL LOADERS: PRODUCTIVITY, EFFICIENCY, SAFETY

## INTRODUCING THE NEW G+ SERIES WHEEL LOADERS

### **G+: The Plus You Can Feel!**

The CASE G Evolution Wheel Loaders just got better.

**More comfort. More safety. More tech. That's the Plus.**

Get ready to take a step forward for the best experience with upgraded G+ Series Wheel Loaders.

G+ is more than evolution.. It's PLUS!



# YOUR EQUIPMENT, YOUR PARTNER

## SIX GOOD REASONS TO CHOOSE CASE WHEEL LOADERS



### 1 SUSTAINABLE POWER

- FPT NEF 6.7 litres (4.5 litres on 521G+), compliant with EU Stage V regulation;
- Turbocharged with variable geometry turbo;
- Hi-pressure common rail electronic injection;
- Hi-eSCR2 exclusive after treatment system, EGRfree;
- HVO diesel and XTL synthetic oils compatible.

### 2 POWERFUL DRIVELINE

- 4-Speed transmission, 5-Speed available;
- Proportional transmission cut-off (power inch): smooth approach; uphill climbing without roll-back; torque converter lock-up for faster acceleration and power loss reduction on 5-speed version;
- Heavy duty axles standard: different combination of front/rear axle differential and multiplesintered bronze brake disk.

### 3 EASE OF OPERATION

- Automated Loader functions with CLICK & DIG;
- Intuitive multifunction touch-screen display;
- Easy boom setup and automatic bucket positioning;
- Three customizable buttons on right console for easy screen page recall;
- Integrated payload scale with tip-off function available;
- Tire pressure monitoring.

### 4 CHAMPION OF EFFICIENCY

- High efficiency “cube design” cooling system allows fresh air to pass through all radiators at the same time without overlaps;
- Optimal weight distribution thanks to rear-positioned engine, resulting in higher loading capacity without increase in operating weight = high productivity with less fuel consumption.

### 5 ENHANCED CONNECTIVITY

- Continuous monitoring of machine health parameters by a team of experts through the SiteConnect module;
- Remote diagnosis and control units updates possible through SiteManager app;
- Easy fleet management through MYCASEConstruction portal, including payload report directly to your desk computer from the machine via telematics.

### 6 MAXIMIZED UPTIME

- All maintenance and refill points in the engine compartment easily reachable from the ground;
- Service intervals at 1000 hours and multiples for reduced maintenance costs.;
- Service alerts generated when maintenance interval is about to expire;
- CaseCare and CaseProtect programs available for full peace-of-mind.

# CLICK & DIG SYSTEM: AUTOMATED POWER, OPERATOR CONTROL

**BOOST PRODUCTIVITY AND EASE OF USE**

**WITH CASE G+ CLICK & DIG AUTOMATED LOADER FUNCTIONS**

- Maximum bucket fill, no calibration needed;
- Consistent performance for all operators;
- Enhanced safety and reduced fatigue;
- Optimized power use for fuel and tire savings.



## **AUTOMATIC DIG FUNCTION**

One click starts a full loading cycle - move, fill, reverse - no pedals or extra controls needed.



## **AUTOMATIC DUMP FUNCTION**

At set boom height, the same trigger dumps the bucket with a shake and auto return-to-dig.



## **AUTOMATIC METERING FUNCTION**

Below horizontal boom angle, trigger activates bucket shake for even material spread.

# GET COMFY AND MOVE THE WORLD

## ALL FUNCTIONALITIES AT YOUR FINGERTIP

The operator's comfort and safety are top priorities for CASE and that's why all its wheel loaders are equipped with a spacious ROPS/FOPS level 2 certified cab, letting you get on with the job at hand untroubled.

### TOUCHSCREEN DISPLAY

The touchscreen display gives operators full control of machine functions and settings, with new features designed to enhance the driving experience.

### INTEGRATED WEIGH LOAD SCALE

Track every bucket load with the integrated payload scale and create complete job tickets with all key details. Send reports instantly to your desk via MYCASEConstruction telematics for faster, smarter job management.

### BEST-IN-CLASS VISIBILITY

Optimal visibility is ensured by:

- One-piece design windshield;
- High efficiency lighting;
- Wide angle rear-view camera (standard);
- Follow-me-home LED lights with customizable lights-on duration.

### TIRE PRESSURE MONITORING

Optional Tire Pressure Monitoring, accessible via the touchscreen, keeps tire status under control—optimizing pressure, reducing wear, and extending tire life.

### SUPERIOR COMFORT

- Seat mounted console;
- Configurable buttons to quickly recall on the display the most frequently used screens;
- Hands-free calling kit;
- Multiple storage areas.

# YOUR SAFETY PARTNER

## INNOVATIVE FEATURES IN EVERY DETAIL

From advanced seating systems to external safety monitoring, rear-view assistance and obstacle detection: the new G+ Series integrates cutting-edge features to protect operators and enhance job site control.



### NEW OPERATOR SEATS

Both standard and Premium seats air suspended, heated and ventilated. Premium seat with 3-points high vis seatbelt, leather coated, auto weight adjustment and low frequency vibration damper.



### NEW EXTERNAL SEATBELT INDICATOR LIGHT

To inform the jobsite supervisor that every operator is working in safe condition.



### NEW REAR-VIEW MIRROR OPTION

Heated and electrically adjustable, also provided with egress light illuminating the cab access steps.

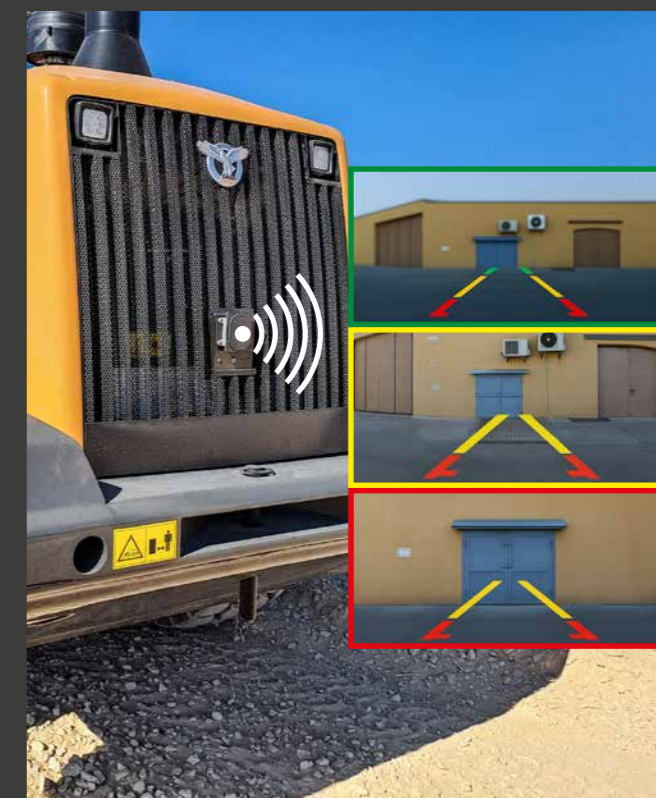

### NEW REAR OBJECT DETECTOR

Provides visual and audible alerts as the distance to a rear obstacle becomes critical.

# CLEANER, GREENER POWER.

## SUSTAINABILITY CHANGES THE WORLD

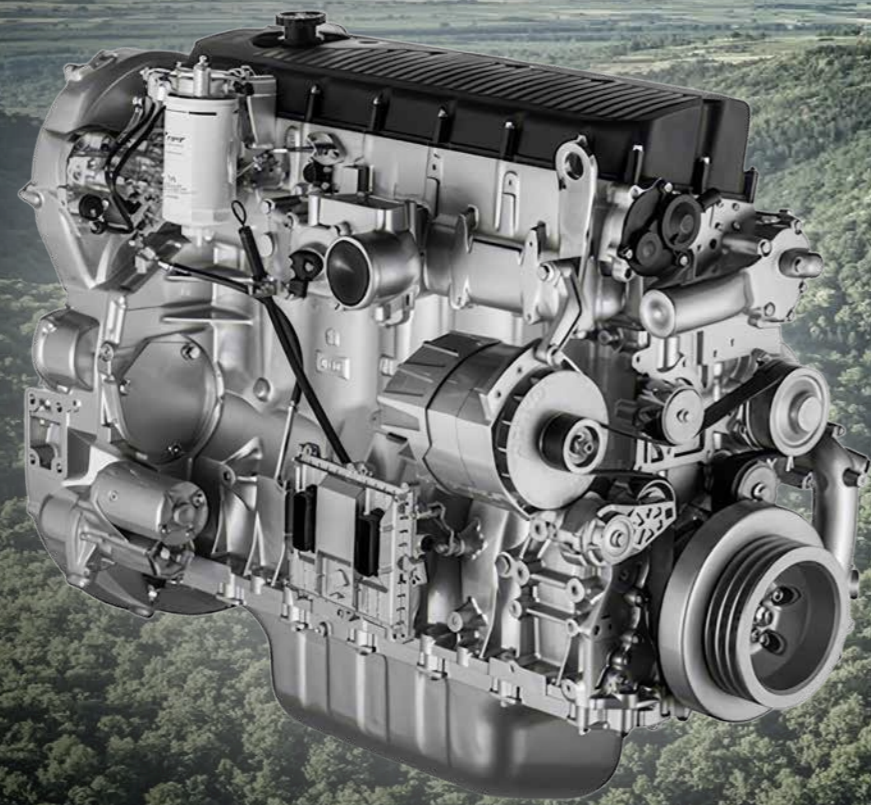

CASE wheel loaders feature advanced engine technology developed by our sister company, FPT Industrial.

Pioneering low-emission, high-efficiency solutions, FPT brings you the competitive advantage of powertrain technologies, reliably delivering high performance with low operating costs.



EU stage V compliant, with exclusive HieSCR2 after treatment system, without EGR, built for life and maintenance free.



FPT Cursor9, 8.7 liters, turbocharged, with variable geometry turbo for optimal pressure stability. Multiple injection high pressure common rail engines.



EGR-free for optimized combustion, resulting in high fuel efficiency in every condition.



Compatible with HVO and all other XTL synthetic fuels (CTL, BTL, GTL) for flexible, sustainable fuel solutions.



Exclusive CASE Cooling Cube design: no radiators overlap ensures high cooling efficiency for the best protection of the entire driveline resulting in reduced TCO.

# MAINTAIN TOP PERFORMANCE

## OUTSTANDING AFTER SALES SERVICES

Keep your equipment performing at its best and protect your investment's value with the extensive offering of high-quality CASE Parts.

### **Genuine Parts** HIGH PERFORMANCE

Optimize your performance and add value to your machine with high-quality genuine parts.

### **Attachments** BUSINESS SOLUTIONS

Add versatility to performance with CASE attachments designed for CASE machines and tested by CASE engineers.

### **FLEETPRO**

Ensure your machine's performance beyond warranty and manage your budget with CASE's quality second-line range of parts.

### **Reman Parts** REMANUFACTURED

Choose sustainable quality with remanufactured parts designed for CASE equipment of all ages.

## **CASE** | ServiceSolutions

Enjoy the peace of mind of knowing CASE Service Solutions will keep your equipment in top condition with maximum uptime, no unexpected costs, and help you optimize your profitability.



### CASE CARE

Maximize your machine's uptime and efficiency with this planned maintenance program.



### CASE PROTECT

Avoid unexpected costs with this extended warranty program.



### CASE FLUID ANALYSIS

Ensure your machine's uptime with detailed fluid reporting.



### myCASEConstruction

Puts the power of centralized fleet management in your hands - through a single, easy-to-use portal and mobile app.



### CASE SITECONNECT

Connects your Dealer to your machine for remote support.



# STANDARD AND OPTIONS

COMMON FEATURES - FULL RANGE	
<b>OPERATOR COMPARTMENT</b>	
Cab air conditioning	●
8" full color touchscreen multifunction display	●
Adjustable seat-mounted electro-hydraulic controls r.h. console	●
Three configurable buttons (quick recall of favorite pages on display)	●
Ride control engagement speed setting (push-button on keypad)	●
Engine throttle lock speed setting (push-button on keypad)	●
Rear window defrosting grid	●
Cab pressurization from the 1 <sup>st</sup> fan speed	●
ROPS (ISO EN13510) and FOPS (ISO EN3449) cab protection	●
Password-protected ignition mode	●
Roof-integrated microphone for hand-free calls (Bluetooth radio requested)	●
USB and AUX ports	●
Multiple storage compartments and cup holder	●
Documents holder	●
Convenience kit including: <ul style="list-style-type: none"> <li>• Rear sunshade</li> <li>• Tray under seat</li> <li>• Additional 24V socket</li> <li>• 2<sup>nd</sup> internal rear-view mirror (left side)</li> <li>• Two coat hooks</li> </ul>	○
Two external rear-view mirror	●
Two external heated and electrically adjustable rear-view mirrors	○
Standard seat, heated and ventilated, air-suspended with high backrest and headrest, cloth coated, 2-pts 2" high visibility seatbelt harness	●
Premium seat including: <ul style="list-style-type: none"> <li>• 3-pts 2" high visibility seatbelt</li> <li>• Active air suspension</li> <li>• Partial leather coating</li> <li>• Wider seat cushion (+ 40 mm)</li> <li>• High backrest with headrest</li> <li>• Wide armrests</li> <li>• Automatic weight adjustment</li> <li>• Low frequency shock absorber</li> <li>• Seat heating and ventilation</li> <li>• Horizontal shock absorber</li> </ul>	○
Radio ready (including wiring and speakers)	●
AM/FM/DAB Radio with Bluetooth	○
Rotating beacon	○
External seat belt indicator (green beacon light)	○
Wide-angle rear-view camera (image automatically displayed when reverse gear is engaged)	●
Rear object detector	○
Joystick, electro-hydraulic, 2 functions	●
Joystick, electro-hydraulic, 3 functions (3 <sup>rd</sup> function controlled by one slider on joystick)	○
Joystick, electro-hydraulic (4 functions, 3 <sup>rd</sup> & 4 <sup>th</sup> functions controlled by two sliders on joystick)	○
Three single axis levers, finger-tip type	○
CLICK & DIG, automated loading, dumping and metering	●
Automatic return-to-dig function adjustable from push-button in the cab	●
Automatic boom height stop adjustable from push-button in the cab	●
Automatic return-to-travel function adjustable from push-button in the cab	●
Standard steering wheel	●
Joystick steering (in addition to standard steering wheel)	○
Integrated payload system with automatic tip-off function, data transmitted in real time to the Customer Portal	○
Integrated Tire Pressure Monitoring System	○

● Standard | ○ options | - N/A

Note: the above table is purely indicative. Configuration and options availability may change according to the defaults agreed with the different EU markets.

COMMON FEATURES - FULL RANGE	
<b>OPERATOR COMPARTMENT</b>	
LED working lights: 2 front + 2 rear	○
LED working lights: 4 front + 2 rear	○
LED working lights: 6 front + 4 rear	○
Halogen driving lights	●
LED driving lights	○
<b>ROAD HOMOLOGATION</b>	
Italian road homologation	○
German/Dutch road homologation (40 km/h)	○
Italian road homologation for ag tires	○
German/Dutch road homologation (40 km/h) ag tires	○
Swedish road homologation	○
<b>CONNECTIVITY</b>	
Advanced connectivity (Dealer dashboard, machine health parameter, maintenance & repair alerts, remote diagnosis)	●
7-Years MyCASEconstruction Customer Portal subscription (Fleet management, real-time payload reports, etc.)	●
<b>MISCELLANEOUS</b>	
Fire extinguisher	○
Empty toolbox	○
Retrieval hitch, mandatory as per EN474	●
Wheel chocks	○
Wide fenders w/lh-rh steps, Swedish homologation	○
Steps on both sides, with full fenders	○
License plate support	○
Side covers on rear chassis	○
Bottom cover (skid plate) on rear chassis	○
Front chassis guard	○
Counterweight, standard	●
Counterweight, heavy-duty	○
Waste handler guards' package, including: <ul style="list-style-type: none"> <li>• Frame articulation covers</li> <li>• Front chassis cover</li> <li>• Transmission bottom guard</li> <li>• Front chassis bottom guard</li> <li>• Hydraulic cylinder guard</li> <li>• Front frame debris ejectors (boom cylinder's room)</li> <li>• Front driving lights protection grids</li> <li>• Rear driving lights protection grids</li> <li>• Fuel tank bottom guard</li> </ul>	○
<i>Note: available on 621G, 651G, 721G, 821G, 921G</i>	
Front windshield protection grid	○
Automatic lubrication system	○
Engine compartment hood electrically openable (521G excluded)	●
External fluids drain ports (engine oil, engine coolant, hydraulic oil)	●
<b>HYDRAULICS / STEERING</b>	
Electrical secondary emergency steering	●
Load sensing variable displacement pump	●
3-Spool load sensing control valve	●
4 <sup>th</sup> Hydraulic function	○
Loader arm suspension (ride control)	●
Quick coupler dedicated circuit	○

● Standard | ○ options | - N/A

Note: the above table is purely indicative. Configuration and options availability may change according to the defaults agreed with the different EU markets.

# STANDARD AND OPTIONS 521G+ | 621G+

FEATURES	521G+		621G+	
	Z-BAR/XR	XT	Z-BAR/XR	XT
<b>ENGINE</b>				
Engine FPT N45 Stage V	●	●	-	-
Engine FPT N67 Stage V	-	-	●	●
Exhaust gases after-treatment Selective Catalyst Reduction on Filter	●	●	●	●
Engine working modes selection (Smart/Max)	●	●	●	●
Air intake rain cap cover (no pre-cleaner)	●	●	●	●
Air intake pre-cleaner	○	○	○	○
Air intake pre-cleaner with dust ejector (Sy-Klone)	○	○	○	○
Standard weather start package	●	●	●	●
Cold weather start package	○	○	○	○
Standard weather package with biodegradable hydraulic oil	○	○	○	○
Cold weather package with biodegradable hydraulic oil	○	○	○	○
Exclusive cooling radiators package (cooling cube) with variable speed reversable hydraulic-driven fan	●	●	●	●
Heavy duty cooling cube, wider radiators cores with variable speed reversable hydraulic-driven fan	○	○	○	○
Remote jump start	●	●	●	●
<b>TRANSMISSION &amp; AXLES</b>				
Powershift Transmission, automatic control 4-speed forward / 3-speed reverse	●	●	●	●
Powershift Transmission, automatic control 5-speed forward / 3-speed reverse with torque converter lock-up and proportional clutch cut-off	-	-	○	○
Transmission control lever on steering column	●	●	●	●
Forward-Neutral-Reverse rocker switch on hydraulic control lever	●	●	●	●
Transmission speed limiter 20 km/h	○	○	○	○
Passive parking brake, electrically disengagement, automatically engaged at engine shut-off	●	●	●	●
Standard axles with limited slip differential front and rear	●	●	●	●
Heavy duty axles with 100% front differential lock and open rear differential	○	○	○	○
Rear axle oscillation limiter	○	○	○	○
<b>TIRES</b>				
L3 Radial XHA 17.5R25 Michelin	○	○	-	-
L3 Radial TB516 17.5R25 Triangle	○	○	-	-
L3 Radial VJT 17.5R25 Bridgestone	●	●	-	-
L3 Radial TB516 20.5R25 Triangle	○	○	○	○
L3 Radial XHA2 20.5R25 Michelin	○	○	○	○
L3 Radial VJT 20.5R25 Bridgestone	○	○	●	●
L2 Radial VSW 20.5R25 Bridgestone	○	○	○	○
L5 Radial XLD-D2 17.5R25 Michelin	○	○	-	-
AG Radial 370 620/70R26 Alliance	○	○	○	○
L5 Radial XLD-D2 20.5R25 Michelin	-	-	○	○
L5 Radial TB538+ 20.5R25 Triangle	-	-	○	○
<b>LOADER LINKAGE &amp; ATTACHMENTS</b>				
Standard Z-Bar linkage	●	-	●	-
XR - Extended reach linkage	○	-	○	-
XT - Parallel linkage	-	●	-	●
Bucket, pin-on, 2.1 m³, 2490 mm wide	○	-	-	-
Bucket, with hydraulic quick coupler, 1.8 m³, 2490 mm wide	○	○	-	-
Hydraulic quick coupler	○	○	○	○
Fork with hydraulic quick coupler	○	○	○	-
Bucket, pin-on, 2.3 m³, 2490 mm wide	-	-	○	○
Bucket, with hydraulic quick coupler, 2.1 m³, 2490 mm wide	-	-	○	○
Bucket teeth	○	○	○	○
Bolt-on reversible cutting edge	○	○	○	○
Teeth + bolt-on cutting edge segments	○	○	○	○
Bucket teeth guard L = 2490 mm	○	○	○	○

● Standard | ○ options | - N/A

Note: the above table is purely indicative. Configuration and options availability may change according to the defaults agreed with the different EU markets.

# STANDARD AND OPTIONS 651G+ | 721G+

FEATURES	651G+		721G+	
	Z-BAR/XR	XT	Z-BAR/XR	XT
<b>ENGINE</b>				
Engine FPT N67 Stage V	●	●	●	●
Exhaust gases after-treatment Selective Catalyst Reduction on Filter	●	●	●	●
Engine working modes selection (Smart/Max)	●	●	●	●
Air intake rain cap cover (no pre-cleaner)	●	●	●	●
Air intake pre-cleaner	○	○	○	○
Air intake pre-cleaner with dust ejector (Sy-Klone)	○	○	○	○
Standard weather start package	●	●	●	●
Cold weather start package	○	○	○	○
Standard weather package with biodegradable hydraulic oil	○	○	○	○
Cold weather package with biodegradable hydraulic oil	○	○	○	○
Exclusive cooling radiators package (cooling cube) with variable speed reversable hydraulic-driven fan	●	●	●	●
Heavy duty cooling cube, wider radiators cores with variable speed reversable hydraulic-driven fan	○	○	○	○
Remote jump start	●	●	●	●
<b>TRANSMISSION &amp; AXLES</b>				
Powershift Transmission, automatic control 4-speed forward / 3-speed reverse	●	●	●	●
Powershift Transmission, automatic control 5-speed forward / 3-speed reverse with torque converter lock-up and proportional clutch cut-off	○	○	○	○
Transmission control lever on steering column	●	●	●	●
Forward-Neutral-Reverse rocker switch on hydraulic control lever	●	●	●	●
Transmission speed limiter 20 km/h	○	○	○	○
Passive parking brake, electrically disengagement, automatically engaged at engine shut-off	●	●	●	●
Heavy duty axles with limited slip differential front and rear	●	●	●	●
Heavy duty axles with front differential lock and open rear differential	○	○	○	○
Heavy duty axles with front differential lock and rear LSD	○	○	○	○
<b>TIRES</b>				
L3 Radial XHA2 20.5R25 (standard width) Michelin	○	○	○	○
L3 Radial XHA2 20.5R25 (narrow width, Italy only) Michelin	-	-	○	○
L3 Radial VJT 20.5R25 (standard width) Bridgestone	●	●	●	●
L3 Radial VJT 20.5R25 (narrow width, Italy only) Bridgestone	-	-	○	○
L3 Radial TB516 20.5R25 (standard width) Triangle	○	○	○	○
L3 Radial TB516 20.5R25 (narrow width, Italy only) Triangle	-	-	○	○
L5 Radial X-MINE D2 20.5R25 (standard width) Michelin	○	○	○	○
L5 Radial X-MINE D2 20.5R25 (narrow width, Italy only) Michelin	-	-	○	○
L5 Radial XLD D2 20.5R25 (standard width) Michelin	○	○	○	○
L5 Radial XLD D2 20.5R25 (narrow width, Italy only) Michelin	-	-	○	○
L5 Radial TB538S+ 20.5R25 (standard width) Triangle	○	○	○	○
L5 Radial TB538S+ 20.5R25 (narrow width, Italy only) Triangle	-	-	○	○
L2 Radial VSW 20.5R25 (narrow width) Bridgestone	○	○	○	○
AG Radial 370 620/70R26 Alliance	○	○	○	○
AG Radial 344 750/55R26.5 Alliance	-	-	○	○
AG Radial MEGAXBIB 750/65R26 Michelin	-	-	○	○
SOLID - S2C2 20.5R25 SG Revol.	-	-	○	○
<b>LOADER LINKAGE &amp; ATTACHMENTS</b>				
Standard Z-Bar linkage	●	-	●	-
XR - Extended reach linkage	-	-	○	-
XT - Parallel linkage	-	●	-	●
Bucket, pin-on, 2.3 m³, 2490 mm wide	○	-	-	-
Bucket, pin-on, 2.6 m³, curved side edges (rehandling, Z-Bar only)	○	-	-	-
Bucket, with hydraulic quick coupler, 2.1 m³, 2490 mm wide	○	○	-	-
Bucket, pin-on, 2.7 m³, 2690 mm wide	-	-	○	○
Bucket, pin-on, 2.5 m³, 2474 mm wide	-	-	○	○
Bucket, pin-on, 3.0 m³, straight side edges (G.P., Z-Bar only)	-	-	○	○
Bucket, pin-on, 3.2 m³, curved side edges (rehandling, Z-Bar only)	-	-	○	○
Bucket, with hydraulic quick coupler, 2.7 m³, 2690 mm wide	-	-	○	○
Bucket, with hydraulic quick coupler, 2.5 m³, 2474 mm wide	-	-	○	○
Hydraulic quick coupler	○	○	○	○
Fork with hydraulic quick coupler	○	○	○	○
Bucket teeth	○	○	○	○
Bolt-on reversible cutting edge	○	○	○	○
Teeth + bolt-on cutting edge segments	○	○	○	○
Bucket teeth guard L=2490 mm	○	○	○	○

FEATURES	821G+	921G+
	Z-BAR/XR	Z-BAR/XR
<b>ENGINE</b>		
Engine FPT N67 Stage V	●	●
Exhaust gases after-treatment Selective Catalyst Reduction on Filter	●	●
Engine working modes selection (Smart/Max)	●	●
Air intake rain cap cover (no pre-cleaner)	●	●
Air intake pre-cleaner	○	○
Air intake pre-cleaner with dust ejector (Sy-Klone)	○	○
Standard weather start package	●	●
Cold weather start package	○	○
Standard weather package with biodegradable hydraulic oil	○	○
Cold weather package with biodegradable hydraulic oil	○	○
Exclusive cooling radiators package (cooling cube) with variable speed reversable hydraulic-driven fan	●	●
Heavy duty cooling cube, wider radiators cores with variable speed reversable hydraulic-driven fan	○	○
Remote jump start	●	●
<b>TRANSMISSION &amp; AXLES</b>		
Powershift Transmission, automatic control 4-speed forward / 3-speed reverse	●	●
Powershift Transmission, automatic control 5-speed forward / 3-speed reverse with torque converter lock-up and proportional clutch cut-off	○	○
Transmission control lever on steering column	●	●
Forward-Neutral-Reverse rocker switch on hydraulic control lever	●	●
Transmission speed limiter 20 km/h	○	○
Passive parking brake, electrically disengagement, automatically engaged at engine shut-off	●	●
Heavy duty axles with limited slip differential front and rear	●	●
Heavy duty axles with front differential lock and open rear differential	○	○
Heavy duty axles with front differential lock and rear LSD	○	○
<b>TIRES</b>		
L3 Radial XHA2 23.5R25 Michelin	○	○
L3 Radial VJT 23.5R25 Bridgestone	●	●
L3 Radial TB516 23.5R25 Triangle	○	○
L5 Radial X-MINE D2 23.5R25 Michelin	○	○
L5 Radial XLD D2 23.5R25 Michelin	○	○
L5 Radial TB538S 23.5R25 Triangle	○	○
L2 Radial VSW 23.5R25 Bridgestone	○	○
AG Radial 370 620/70R26 Alliance	○	○
AG Radial 344 750/55R26.5 Alliance	-	○
AG Radial CEREXBIB 710/65R30 Michelin	-	○
SOLID - S2C2 23.5R25 SG Revolution	-	○
<b>LOADER LINKAGE &amp; ATTACHMENTS</b>		
Standard Z-Bar linkage	●	●
XR - Extended reach linkage	○	○
Bucket, pin-on, 3.4 m³, 2946 mm wide	○	-
Bucket, pin-on, 3.6 m³, curved side edges (rehandling, Z-Bar only)	○	-
Bucket, with hydraulic quick coupler, 3.4 m³, 2946 mm wide	○	○
Bucket, pin-on, 4.2 m³, curved side edges (rehandling, Z-Bar only)	-	○
Hydraulic quick coupler	○	○
Fork with hydraulic quick coupler	○	○
Bucket teeth	○	○
Bolt-on reversible cutting edge	○	○
Teeth + bolt-on cutting edge segments	○	○
Bucket teeth guard L=2490 mm	○	○

● Standard | ○ options | - N/A

Note: the above table is purely indicative. Configuration and options availability may change according to the defaults agreed with the different EU markets.

Table 1/2

SPECIFICATIONS	521G+	621G+	651G+	721G+	821G+	921G+
<b>ENGINE</b>						
Maker & Model	FTP N45	FTP N67	FTP N67	FPT N67	FPT N67	FPT N67
No. of cylinders	4	6	6	6	6	6
Displacement	l 4.5	6.7	6.7	6.7	6.7	6.7
Air intake	Turbocharger with air-to-air cooling. No EGR valve is used: Only fresh air is taken for combustion and no extra cooling system is needed.					
Injection	Common Rail Multiple Injection.					
After Treatment System	HI-eSCR 2 (DOC+SCRoF)					
Emissions Level	Compliant with EU Stage V					
Maximum power (Peak Gross/Peak Net)	kW	106/99	128/121	128/121	145	172
Maximum power (Peak Gross/Peak net)	hp	142/133	172/162	172/162	195	230
@ Engine speed (ISO 14396)	rpm	1800	1800	1800	2000	1800
Maximum Torque (Gross/Net)	Nm	612/586	730/692	730/692	950	1184
@ Engine speed (ISO 14396)	rpm	1600	1600	1600	1300	1300
<b>TRANSMISSION</b>						
ProShift: 5-speed powershift with lock up (optional). Lock up clutch eliminates torque converter losses from second gear up to fifth gear. Intelligent Clutch Cut Off (ICCO) with Power Inch: Proportional declutching.						
• Forward 1	km/h	-	7	7	7	6
• Forward 2	km/h	-	13	13	11	11
• Forward 3	km/h	-	20	20	17	17
• Forward 4	km/h	-	31	31	26	26
• Forward 5	km/h	-	45	45	40	40
• Reverse 1	km/h	-	7	7	7	7
• Reverse 2	km/h	-	14	14	12	12
• Reverse 3	km/h	-	32	32	28	28
<b>4-speed ZF Powershift with Intelligent Clutch Cut Off (ICCO)</b>						
• Forward 1	km/h	6	7	7	7	7
• Forward 2	km/h	11	13	13	12	12
• Forward 3	km/h	22	24	24	23	23
• Forward 4	km/h	36	39	39	37	36
• Reverse 1	km/h	6	7	7	7	7
• Reverse 2	km/h	12	14	14	13	13
• Reverse 3	km/h	23	25	25	25	25
<b>AXLES (available options)</b>						
Heavy Duty ZF Axles with Limited Slip Differential on both front and rear axle	n.a.	yes	yes	yes	yes	n.a.
Heavy Duty ZF Axles with automatic 100% differential lock on front and open	yes	yes	yes	yes	yes	yes
Heavy Duty ZF Axles with automatic 100% differential lock on front and LSD on rear axle	n.a.	yes	yes	yes	yes	n.a.
Standard ZF Axles with Limited Slip Differential on both front and rear axle	yes	yes	n.a.	n.a.	n.a.	n.a.
Axles oscillation angle (total)	°	24	24	24	24	24
<b>TIRES</b>						
Standard tire's size	17.5R25	20.5R25	20.5R25	20.5R25	23.5R25	23.5R25

# SPEC SHEET

Table 2/2

SPECIFICATIONS		521G+	621G+	651G+	721G+	821G+	921G+
<b>BRAKES</b>							
Service brake		Maintenance free, self-adjusting wet 4-wheel disc brakes.					
Service brake disc area	m <sup>2</sup> /hub	0.31	0.39	0.39	0.39	0.39	0.47
Parking brake		With the negative brake all four wheels are automatically stopped when the engine is stopped.					
Parking brake disc area	cm <sup>2</sup>	58	58	58	82	82	82
<b>HYDRAULICS</b>							
Loader control valve		Bosch-Rexroth, closed center, load sensing/flow sharing.					
Steering		Steering cylinders actuated by hydraulic orbitrol under priority valve, controlled, in turn, by active load sensing signal.					
Loader controls		Pilot with proportional solenoid valves controlled by electro-hydraulic single joystick or single-axis 2/3 levers.					
Pump type		Single, variable displacement			Tandem, variable displacement		
Max oil flow	l/min	134	169	190	206	236	278
@ engine speed	rpm	2000	2000	2000	2000	2000	2000
<b>AUXILIARY HYDRAULICS</b>							
Max oil flow	l/min	134	169	188	206	236	278
Max pressure	bar	249-255	249-255	249-255	249-255	249-255	249-255
<b>FLUIDS CAPACITIES</b>							
Fuel tank	l	189	248	248	246	288	288
DEF (AdBlue®) tank	l	41.3	41.3	41.3	41.3	41.3	41.3
Engine coolant	l	22	27	27	28	30	30
Engine oil	l	12	13	13	13	13	13
Hydraulic oil tank	l	57	91	91	91	91	91
Total hydraulic system oil	l	114	148	148	180	180	200
Front and rear axles	l	22+22	22+22	22+22	35+35	40+40	42+40
Transmission oil	l	19	27	27	34	34	34
<b>CAB PROTECTION</b>							
Protection against falling objects (FOPS)		According to ISO EN 3449 std.					
Protection against roll-over (ROPS)		According to ISO EN 13510 std.					
<b>NOISE AND VIBRATIONS</b>							
Inside the cab - LpA (ISO 6396-2008)	dB	68	68	68	68	68	69
Outside - LwA (2000/14/EC)	dB	102	104	104	103	104	104
Vibrations		Operator's seat meets the criteria of ISO 7096:2000. The vibrations transmitted do not exceed 0.5 m/s <sup>2</sup>					
<b>ELECTRICAL SYSTEM</b>							
System voltage	V	24	24	24	24	24	24
Batteries	n° x V	2 x 12	2 x 12	2 x 12	2 x 12	2 x 12	2 x 12
Alternator - capacity	A	70	120	120	120	120	120

# LOADER SPECIFICATIONS 521G+ BUCKETS, Z-BAR & XR

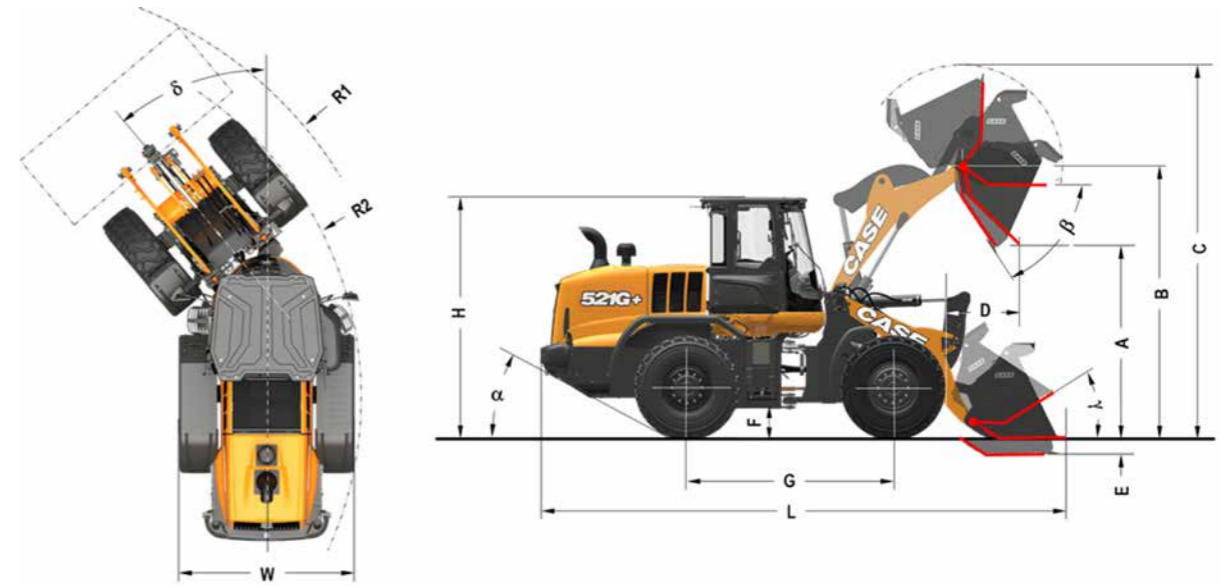

DIMENSION - Data with factory-fitted buckets	G.P. PIN-ON				G.P. QUICK COUPLER				
	Z-Bar		XR		Z-Bar		XR		
Bucket accessory	B.O.E.	Teeth	B.O.E.	Teeth	B.O.E.	Teeth	B.O.E.	Teeth	
Bucket Rated Capacity:	m <sup>3</sup>	2.1	2	1.9	1.8	1.8	1.7	1.8	1.7
Bucket Capacity at 110% Fill Factor	m <sup>3</sup>	2.3	2.2	2.1	2	2	1.9	2	1.9
Bucket overall width	mm	2497	2540	2497	2540	2497	2540	2497	2540
Bucket weight	kg	847	794	813	759	1052	998	1052	998
A Dump height at 45° @ full boom height	mm	2612	2548	3040	2979	2482	2412	2922	2856
B Bucket hinge pin height	mm	3605	3605	3985	3985	3605	3605	3985	3985
C Overall height	mm	4743	4743	5061	5061	4740	4740	5120	5120
D Bucket reach, 45° dump @ full boom height	mm	1114	1188	1044	1121	1069	1135	1127	1199
E Digging depth	mm	83	85	108	108	102	105	137	140
F Ground clearance	mm	341	341	341	341	341	341	341	341
G Wheel base	mm	2750	2750	2750	2750	2750	2750	2750	2750
H Cab roof height	mm	3275	3275	3275	3275	3275	3275	3275	3275
W Overall vehicle width (without bucket)	mm	2448	2448	2448	2448	2448	2448	2448	2448
L Overall length on ground (with bucket)	mm	6838	6937	7111	7207	6930	7030	7272	7371
alpha Departure angle	°	30	30	30	30	30	30	30	30
R2 Turning radius (at outer wheel)	mm	5002	5002	5002	5002	5002	5002	5002	5002
R1 Turning radius (at bucket corner, max reach)	mm	5524	5573	5667	5717	5523	5570	5688	5737
delta Full steering angle	°	±40	±40°	±40	±40	±40	±40	±40	±40
gamma Bucket rollback angle @ boom carry position	°	44	44	46	46	50	50	51	51
beta Bucket dump angle @ maximum boom height	°	55	55	51	51	45	45	40	40
<b>LOADER PERFORMANCE</b>									
Bucket accessory		B.O.E.	Teeth	B.O.E.	Teeth	B.O.E.	Teeth	B.O.E.	Teeth
Machine operating weight (w/17.5R25 L3 tires)	kg	11098	11045	11192	11138	11303	11250	11431	11377
Tipping load, straight	kg	8758	8827	7560	7627	8418	8570	7184	7314
Tipping load, full turn	kg	7673	7743	6601	6668	7354	7496	6246	6367
Maximum payload	kg	3837	3871	3301	3334	3677	3748	3123	3183
Maximum material density	kg/m <sup>3</sup>	1827	1955	1756	1873	2104	2256	1787	1917
Bucket break-out force	daN	7455	8183	7976	8797	7155	7518	6883	7515
<b>CYCLE TIMES</b>									
Lift (full load)	sec	5.4		5.4		5.4		5.4	
Dump (full load)	sec	1.2		2.4		1.2		2.4	
Lowering (empty, float down)	sec	3.9		3.9		3.9		3.9	

All units equipped with std.\* L3 Radial Tires (Unless Noted), ROPS cab with Heater and A/C, Heavy Counterweight, Front and Rear Fenders, Full Fuel and DEF tanks, 75 kg operator. Specifications per ISO 14397, ISO 5998 AND ISO 7546.

\* STD Tires size per model: 521G: 17.5R25 | 621G-651G-721G: 20.5R25 | 821G-921G: 23.5R25

# LOADER SPECIFICATIONS 621G+ BUCKETS, Z-BAR & XR

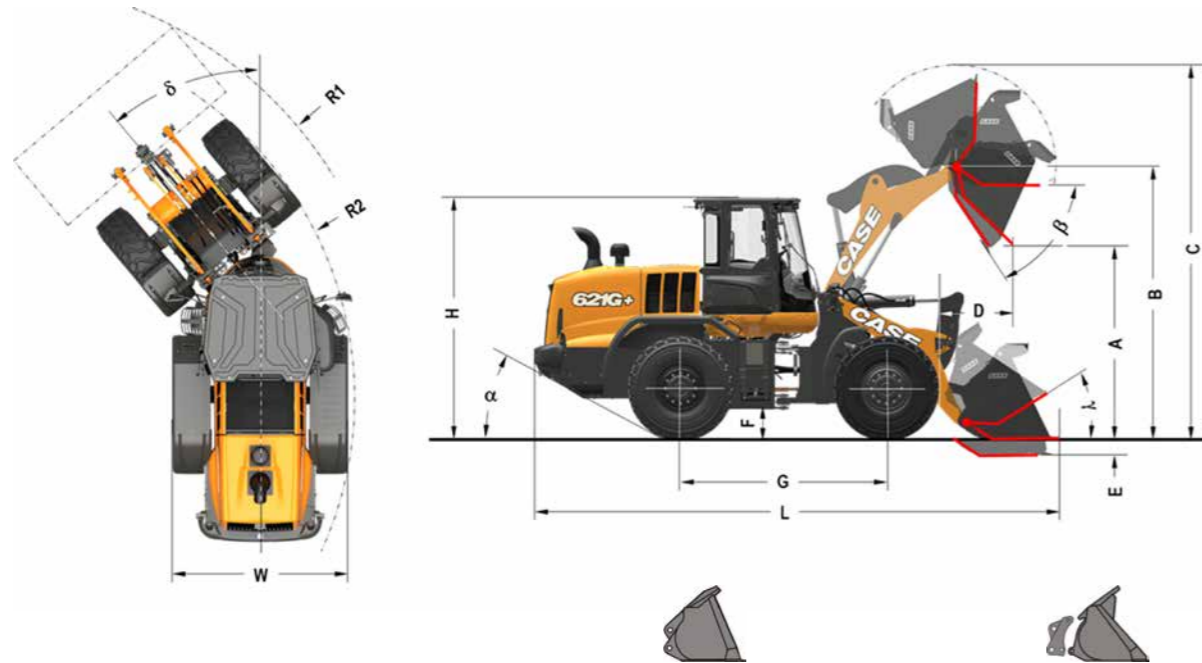

DIMENSION - Data with factory-fitted buckets	G.P. PIN-ON				G.P. QUICK COUPLER				
	Z-Bar		XR		Z-Bar		XR		
Bucket accessory	B.O.E.	Teeth	B.O.E.	Teeth	B.O.E.	Teeth	B.O.E.	Teeth	
Bucket Rated Capacity:	m³	2.3	2.2	2.3	2.2	2	1.9	2.0	1.9
Bucket Capacity at 110% Fill Factor	m³	2.5	2.4	2.5	2.4	2.2	2.1	2.2	2.1
Bucket overall width	mm	2497	2540	2497	2540	2497	2540	2497	2540
Bucket weight	kg	924	871	924	871	1377	1323	1377	1323
A Dump height at 45° @ full boom height	mm	2745	2682	3273	3179	2697	2628	3216	3154
B Bucket hinge pin height	mm	3833	3833	4258	4258	3832	3832	4256	4256
C Overall height	mm	5044	5044	5469	5469	5051	5051	5476	5476
D Bucket reach, 45° dump @ full boom height	mm	1073	1147	1074	1148	1104	1181	1213	1296
E Digging depth	mm	86	87	90	92	87	90	92	95
F Ground clearance	mm	389	389	389	389	389	389	389	389
G Wheel base	mm	2900	2900	2900	2900	2900	2900	2900	2900
H Cab roof height	mm	3384	3384	3384	3384	3384	3384	3384	3384
W Overall vehicle width (without bucket)	mm	2478	2478	2478	2478	2478	2478	2478	2478
L Overall length on ground (with bucket)	mm	7469	7567	7877	7976	7527	7633	7935	8041
α Departure angle	°	25	25	25	25	25	25	25	25
R2 Turning radius (at outer wheel)	mm	5223	5223	5223	5223	5223	5223	5223	5223
R1 Turning radius (at bucket corner, max reach)	mm	5758	5807	5961	6014	5744	5792	5940	5992
δ Full steering angle	°	±40	±40	±40	±40	±40	±40	±40	±40
γ Bucket rollback angle @ boom carry position	°	45	45	45	45	50	50	51	51
β Bucket dump angle @ maximum boom height	°	51	51	45	45	41	41	35	35
<b>LOADER PERFORMANCE</b>									
Bucket accessory	B.O.E.	Teeth	B.O.E.	Teeth	B.O.E.	Teeth	B.O.E.	Teeth	
Machine operating weight (w/L3 tires)	kg	12878	12824	13059	13006	13330	13277	13512	13548
Tipping load, straight	kg	10662	10740	8957	9026	10134	10296	8464	8598
Tipping load, full turn	kg	9248	9319	7729	7798	8737	8886	7249	7372
Maximum payload	kg	4724	4659	3960	4003	4369	4443	3624	3686
Maximum material density	kg/m³	2011	2109	1681	1765	2148	2297	1782	1906
Bucket break-out force	daN	9907	10765	11672	12427	9268	9982	9295	10007
<b>CYCLE TIMES</b>									
Lift (full load)	sec	6.3		6.3		6.3		6.3	
Dump (full load)	sec	1.2		1.2		1.2		1.2	
Lowering (empty, float down)	sec	4.8		4.8		4.8		4.8	

All units equipped with std.\* L3 Radial Tires (Unless Noted), ROPS cab with Heater and A/C, Heavy Counterweight, Front and Rear Fenders, Full Fuel and DEF tanks, 75 kg operator. Specifications per ISO 14397, ISO 5998 AND ISO 7546.

\* STD Tires size per model: 521G: 17.5R25 | 621G-651G-721G: 20.5R25 | 821G-921G: 23.5R25

# LOADER SPECIFICATIONS 651G+ BUCKETS, Z-BAR & XR

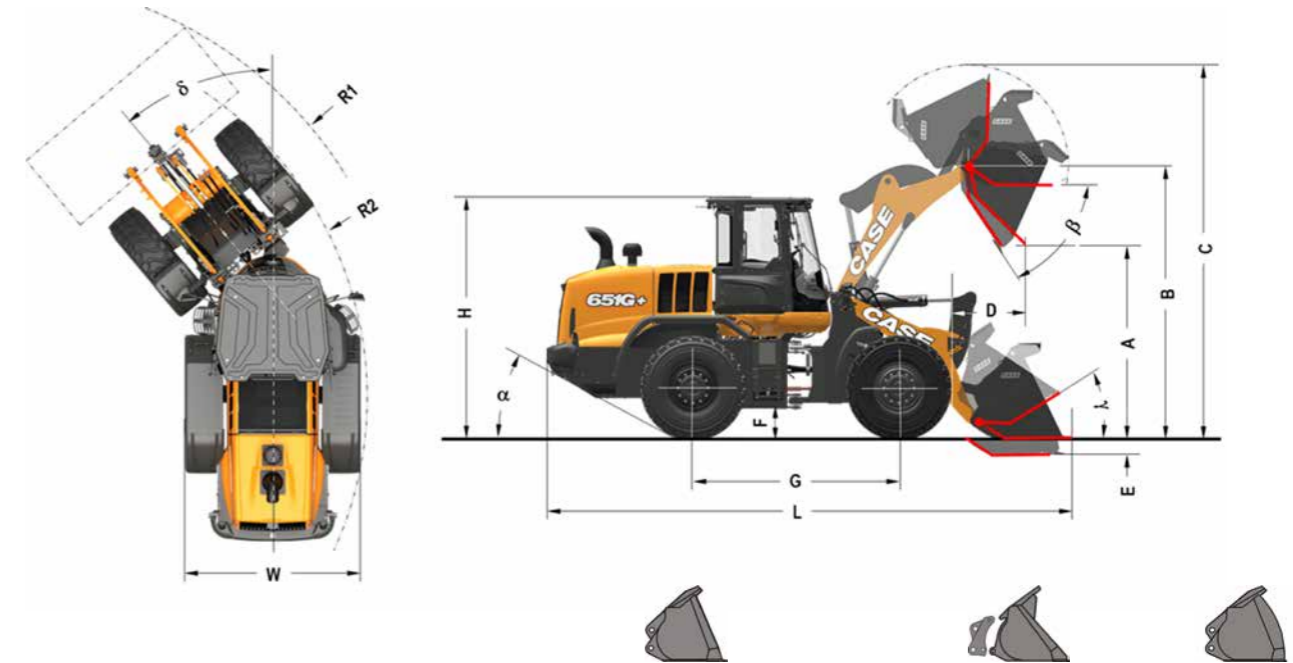

DIMENSION - Data with factory-fitted buckets	G.P. PIN-ON				G.P. QUICK COUPLER				REHANDL	
	Z-Bar		XR		Z-Bar		XR			
Bucket accessory	B.O.E.	Teeth	B.O.E.	Teeth	B.O.E.	Teeth	B.O.E.	Teeth	B.O.E.	
Bucket Rated Capacity:	m³	2.3	2.2	2.3	2.2	2	1.9	2	1.9	2.6
Bucket Capacity at 110% Fill Factor	m³	2.5	2.4	2.5	2.4	2.2	2	2.2	2	2.9
Bucket overall width	mm	2497	2540	2497	2540	2497	2540	2497	2540	2540
Bucket weight	kg	924	871	924	871	1377	1323	1377	1323	1087
A Dump height at 45° @ full boom height	mm	2850	2786	3331	3272	2860	2795	3386	3329	2821
B Bucket hinge pin height	mm	3938	3938	4363	4363	3936	3937	4361	4361	3938
C Overall height	mm	5149	5149	5574	5574	5156	5156	5580	5580	5362
D Bucket reach, 45° dump @ full boom height	mm	953	1026	993	1070	1053	1134	1128	1215	896
E Digging depth	mm	62	63	61	62	64	67	62	65	72
F Ground clearance	mm	389	389	389	389	389	389	389	389	389
G Wheel base	mm	2900	2900	2900	2900	2900	2900	2900	2900	2900
H Cab roof height	mm	3384	3384	3384	3384	3384	3384	3384	3384	3384
W Overall vehicle width (without bucket)	mm	2478	2478	2478	2478	2478	2478	2478	2478	2478
L Overall length on ground (with bucket)	mm	7472	7570	7880	7978	7530	7636	7938	8043	7466
α Departure angle	°	25	25	25	25	25	25	25	25	25
R2 Turning radius (at outer wheel)	mm	5223	5223	5223	5223	5223	5223	5223	5223	5223
R1 Turning radius (at bucket corner, max reach)	mm	5758	5807	5961	6014	5744	5792	5940	5992	5764
δ Full steering angle	°	±40	±40	±40	±40	±40	±40	±40	±40	±40
γ Bucket rollback angle @ boom carry position	°	45	45	45	45	50	50	51	51	43
β Bucket dump angle @ maximum boom height	°	47	47	41	41	37	37	31	31	42
<b>LOADER PERFORMANCE</b>										
Bucket accessory	B.O.E.	Teeth	B.O.E.	Teeth	B.O.E.	Teeth	B.O.E.	Teeth	B.O.E.	
Machine operating weight (w/L3 tires)	kg	14062	14009	14244	14190	14515	14461	14696	14643	14225
Tipping load, straight	kg	11943	12014	10171	10140	11400	11573	9568	9710	11722
Tipping load, full turn	kg	10340	10411	8680	8748	9816	9974	8189	320	10128
Maximum payload	kg	5170	5205	4340	4374	4908	4987	4095	4160	5064
Maximum material density	kg/m³	2248	2356	1887	1980	2414	2579	1832	1958	1948
Bucket break-out force	daN	9909	10766	10188	11066	9265	9978	9290		9217
<b>CYCLE TIMES</b>										
Lift (full load)	sec	5.5		5.5		5.5		5.5		5.5
Dump (full load)	sec	1.1		1.1		1.1		1.1		1.1
Lowering (empty, float down)	sec	4.3		4.3		4.3		4.3		4.3

All units equipped with std.\* L3 Radial Tires (Unless Noted), ROPS cab with Heater and A/C, Heavy Counterweight, Front and Rear Fenders, Full Fuel and DEF tanks, 75 kg operator. Specifications per ISO 14397, ISO 5998 AND ISO 7546.

\* STD Tires size per model: 521G: 17.5R25 | 621G-651G-721G: 20.5R25 | 821G-921G: 23.5R25

# LOADER SPECIFICATIONS 721G+

## BUCKETS, Z-BAR & XR

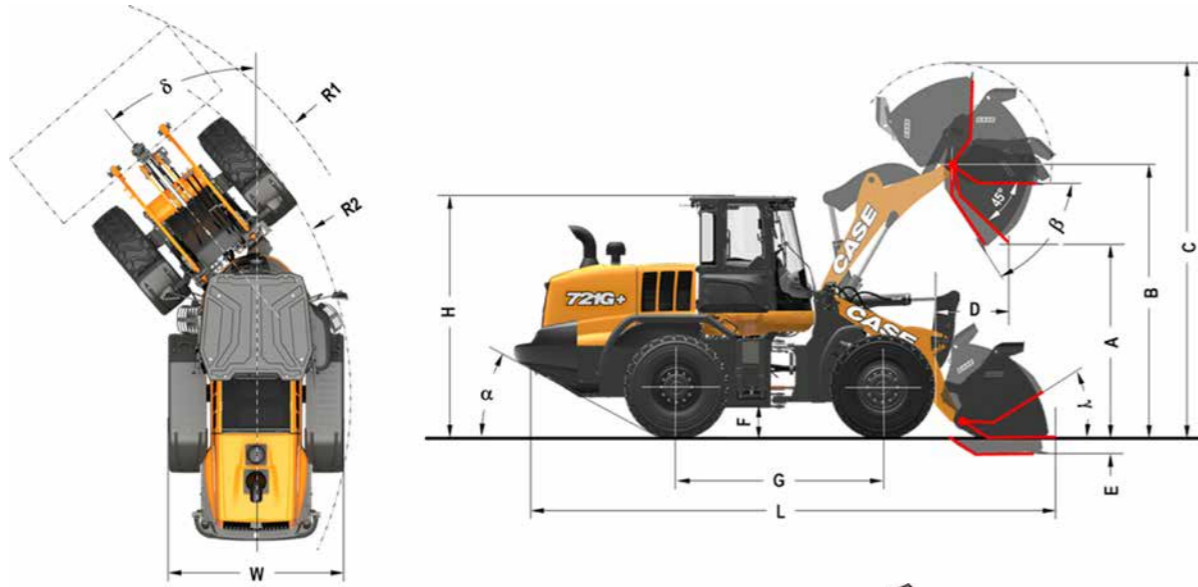

Table 1/2

DIMENSION - Data with factory-fitted buckets	G.P. PIN-ON								
	Z-Bar		Z-Bar		XR		XR		
Bucket accessory	B.O.E.	Teeth	B.O.E.	Teeth	B.O.E.	Teeth	B.O.E.	Teeth	
Bucket Rated Capacity:	m <sup>3</sup>	2.7	2.6	3	2.9	2.5	2.4	2.7	2.6
Bucket Capacity at 110% Fill Factor	m <sup>3</sup>	3	2.9	3.3	3.2	2.7	2.6	3	2.9
Bucket overall width	mm	2712	2726	2740	2740	2494	2510	2712	2726
Bucket weight	kg	1221	1202	1410	1356	1155	1134	1221	1202
A Dump height at 45° @ full boom height	mm	3031	2932	2883	2782	3429	3330	3429	3330
B Bucket hinge pin height	mm	4079	4079	4079	4079	4477	4477	4477	4477
C Overall height	mm	5429	5429	5613	5613	5827	5827	5827	5827
D Bucket reach, 45° dump @ full boom height	mm	1015	1111	1074	1166	990	1086	990	1086
E Digging depth	mm	52	66	67	80	48	62	48	62
F Ground clearance	mm	384	384	384	384	384	384	384	384
G Wheel base	mm	3253	3253	3253	3253	3253	3253	3253	3253
H Cab roof height	mm	3378	3378	3378	3378	3378	3378	3378	3378
W Overall vehicle width (without bucket)	mm	2558	2558	2558	2558	2558	2558	2558	2558
L Overall length on ground (with bucket)	mm	7661	7809	7826	7973	8019	8165	8019	8165
alpha Departure angle	°	29	29	29	29	29	29	29	29
R2 Turning radius (at outer wheel)	mm	5748	5748	5748	5748	5748	5748	5748	5748
R1 Turning radius (at bucket corner, max reach)	mm	6324	6373	6373	6418	6398	6455	6495	6551
delta Full steering angle	°	±40	±40	±40	±40	±40	±40	±40	±40
gamma Bucket rollback angle @ boom carry position	°	44	44	42	42	43	43	43	43
beta Bucket dump angle @ max boom height	°	47	47	42	42	47	47	47	47
<b>LOADER PERFORMANCE</b>									
Bucket accessory	B.O.E.	Teeth	B.O.E.	Teeth	B.O.E.	Teeth	B.O.E.	Teeth	
Machine operating weight (w/L3 tires)	kg	15642	15623	15831	15777	15779	15757	15845	15826
Tipping load, straight	kg	13686	13711	12923	12993	11612	11640	11542	11566
Tipping load, full turn	kg	11467	11492	10802	10872	8897	9784	9651	9675
Maximum payload	kg	5734	5746	5401	5436	4860	4874	4825	4837
Maximum material density	kg/m <sup>3</sup>	2093	2185	1802	1824	1929	2040	1761	1840
Bucket break-out force	daN	14321	15409	11671	10699	14315	15406	142772	15370
<b>CYCLE TIMES</b>									
Lift (full load)	sec	5.2		5.2		5.2		5.2	
Dump (full load)	sec	1.2		1.2		1.2		1.2	
Lowering (empty, float down)	sec	2.4		2.4		2.4		2.4	

All units equipped with std.\* L3 Radial Tires (Unless Noted), ROPS cab with Heater and A/C, Heavy Counterweight, Front and Rear Fenders, Full Fuel and DEF tanks, 75 kg operator. Specifications per ISO 14397, ISO 5998 AND ISO 7546.

\* STD Tires size per model: 521G: 17.5R25 | 621G-651G-721G: 20.5R25 | 821G-921G: 23.5R25

Table 2/2

DIMENSION - Data with factory-fitted buckets	G.P QUICK COUPLER				REHANDLING	
	Z-Bar		XR		Z-Bar	
Bucket accessory	B.O.E.	Teeth	B.O.E.	Teeth	B.O.E.	Teeth
Bucket Rated Capacity	m <sup>3</sup>	2.7	2.6	2.5	2.4	3.2
Bucket Capacity at 110% Fill Factor	m <sup>3</sup>	3	2.8	2.7	2.6	3.5
Bucket overall width	mm	2712	2726	2494	2510	2740
Bucket weight	kg	1745	1726	1155	1134	1424
A Dump height at 45° @ full boom height	mm	2839	2732	3429	3330	2883
B Bucket hinge pin height	mm	4078	4078	4477	4477	4078
C Overall height	mm	5452	5452	5827	5827	5613
D Bucket reach, 45° dump @ full boom height	mm	1062	1149	990	1086	1074
E Digging depth	mm	41	55	48	62	67
F Ground clearance	mm	384	384	384	384	384
G Wheel base	mm	3253	3253	3253	3253	3253
H Cab roof height	mm	3378	3378	3378	3378	3378
W Overall vehicle width (without bucket)	mm	2558	2558	2558	2558	2558
L Overall length on ground (with bucket)	mm	7841	7989	8019	8165	7827
alpha Departure angle	°	29	29	29	29	29
R2 Turning radius (at outer wheel)	mm	5748	5748	5748	5748	5748
R1 Turning radius (at bucket corner, max reach)	mm	6405	6460	6398	6455	6373
delta Full steering angle	°	±40	±40	±40	±40	±40
gamma Bucket rollback angle @ boom carry position	°	38	38	43	43	42
beta Bucket dump angle @ maximum boom height	°	48	48	47	47	42
<b>LOADER PERFORMANCE</b>						
Bucket accessory	B.O.E.	Teeth	B.O.E.	Teeth	B.O.E.	Teeth
Machine operating weight (w/L3 tires)	kg	16166	16147	15779	15757	15845
Tipping load, straight	kg	12003	12134	11612	11640	12867
Tipping load, full turn	kg	9988	10099	9721	9748	10752
Maximum payload	kg	4994	5049	4860	4874	5376
Maximum material density	kg/m <sup>3</sup>	1845	1937	1929	2040	1679
Bucket break-out force	daN	11889	11900	14315	15405	11669
<b>CYCLE TIMES</b>						
Lift (full load)	sec	5.2		5.2		5.2
Dump (full load)	sec	1.2		1.2		1.2
Lowering (empty, float down)	sec	2.4		2.4		2.4

All units equipped with std.\* L3 Radial Tires (Unless Noted), ROPS cab with Heater and A/C, Heavy Counterweight, Front and Rear Fenders, Full Fuel and DEF tanks, 75 kg operator. Specifications per ISO 14397, ISO 5998 AND ISO 7546.

\* STD Tires size per model: 521G: 17.5R25 | 621G-651G-721G: 20.5R25 | 821G-921G: 23.5R25

# LOADER SPECIFICATIONS 821G+

## BUCKETS, Z-BAR & XR

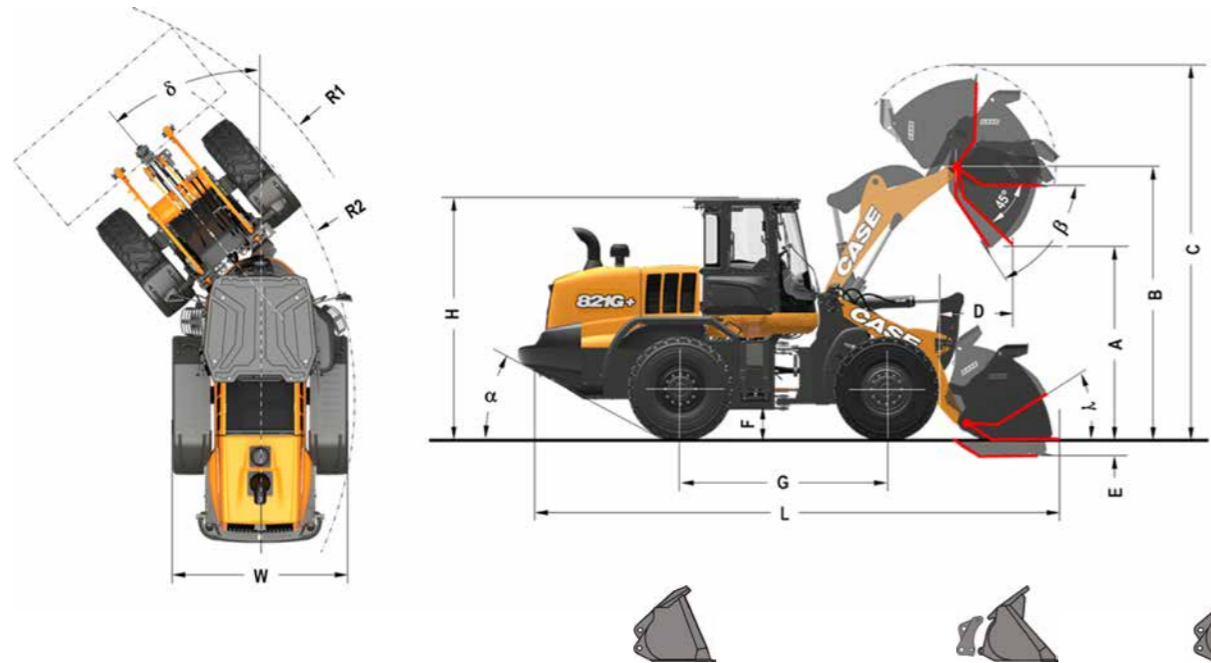

DIMENSION - Data with factory-fitted buckets	G.P. PIN-ON				G.P. QUICK COUPLER				REHANDL.	
	Z-Bar		XR		Z-Bar		XR			
Bucket accessory	B.O.E.	Teeth	B.O.E.	Teeth	B.O.E.	Teeth	B.O.E.	Teeth	B.O.E.	
Bucket Rated Capacity:	m <sup>3</sup>	3.4	3.2	3.2	3	3.2	3.1	3.2	3.1	3.6
Bucket Capacity at 110% Fill Factor	m <sup>3</sup>	3.7	3.5	3.5	3.3	3.5	3.4	3.5	3.4	3.9
Bucket overall width	mm	2946	2983	2946	2983	2983	2983	2946	2983	2990
Bucket weight	kg	1568	1551	1539	1521	2638	2620	2638	2620	1650
A Dump height at 45° @ full boom height	mm	2932	2852	3394	3313	2727	2639	3172	3085	2914
B Bucket hinge pin height	mm	4120	4120	4561	4561	4116	4116	4558	4558	4120
C Overall height	mm	5483	5483	5890	5890	5990	5990	6031	6031	5731
D Bucket reach, 45° dump @ full boom height	mm	1166	1146	1253	1335	1184	1258	1303	1378	976
E Digging depth	mm	74	84	141	151	77	86	144	153	90
F Ground clearance	mm	390	390	390	390	390	390	390	390	390
G Wheel base	mm	3340	3340	3340	3340	3340	3340	3340	3340	3340
H Cab roof height	mm	3380	3380	3380	3380	3380	3380	3380	3380	3380
W Overall vehicle width (without bucket)	mm	2829	2829	2829	2829	2829	2829	2829	2829	2829
L Overall length on ground (with bucket)	mm	8082	8202	8535	8650	8261	8382	8746	8867	7993
α Departure angle	°	29	29	29	29	29	29	29	29	29
R2 Turning radius (at outer wheel)	mm	6030	6030	6030	6030	6030	6030	6030	6030	6030
R1 Turning radius (at bucket corner, max reach)	mm	6629	6681	6868	6927	6685	6739	6945	7006	6615
δ Full steering angle	°	±40	±40	±40	±40	±40	±40	±40	±40	±40
γ Bucket rollback angle @ boom carry position	°	45	45	43	43	44	44	43	43	45
β Bucket dump angle @ maximum boom height	°	55	55	49	49	51	51	45	45	50
<b>LOADER PERFORMANCE</b>										
Bucket accessory	B.O.E.	Teeth	B.O.E.	Teeth	B.O.E.	Teeth	B.O.E.	Teeth	B.O.E.	
Machine operating weight (w/L3 tires)	kg	18329	18311	18556	18549	19397	19380	19665	19647	18411
Tipping load, straight	kg	14880	14904	11941	11964	13162	13229	10420	10472	14914
Tipping load, full turn	kg	12472	12495	9944	10016	10886	10945	8561	8608	12481
Maximum payload	kg	6236	6248	4997	5008	5443	5472	4281	4304	6240
Maximum material density	kg/m <sup>3</sup>	1873	1947	1567	1626	1710	1745	1345	1372	1719
Bucket break-out force	daN	14752	15722	15395	16411	12563	13282	12797	13526	14784
<b>CYCLE TIMES</b>										
Lift (full load)	sec	6.2		6.2		6.2		6.2		6.2
Dump (full load)	sec	1.2		1.2		1.2		1.2		1.2
Lowering (empty, float down)	sec	2.5		2.5		2.5		2.5		2.5

All units equipped with std.\* L3 Radial Tires (Unless Noted), ROPS cab with Heater and A/C, Heavy Counterweight, Front and Rear Fenders, Full Fuel and DEF tanks, 75 kg operator. Specifications per ISO 14397, ISO 5998 AND ISO 7546.

\* STD Tires size per model: 521G: 17.5R25 | 621G-651G-721G: 20.5R25 | 821G-921G: 23.5R25

# LOADER SPECIFICATIONS 921G+

## BUCKETS, Z-BAR & XR

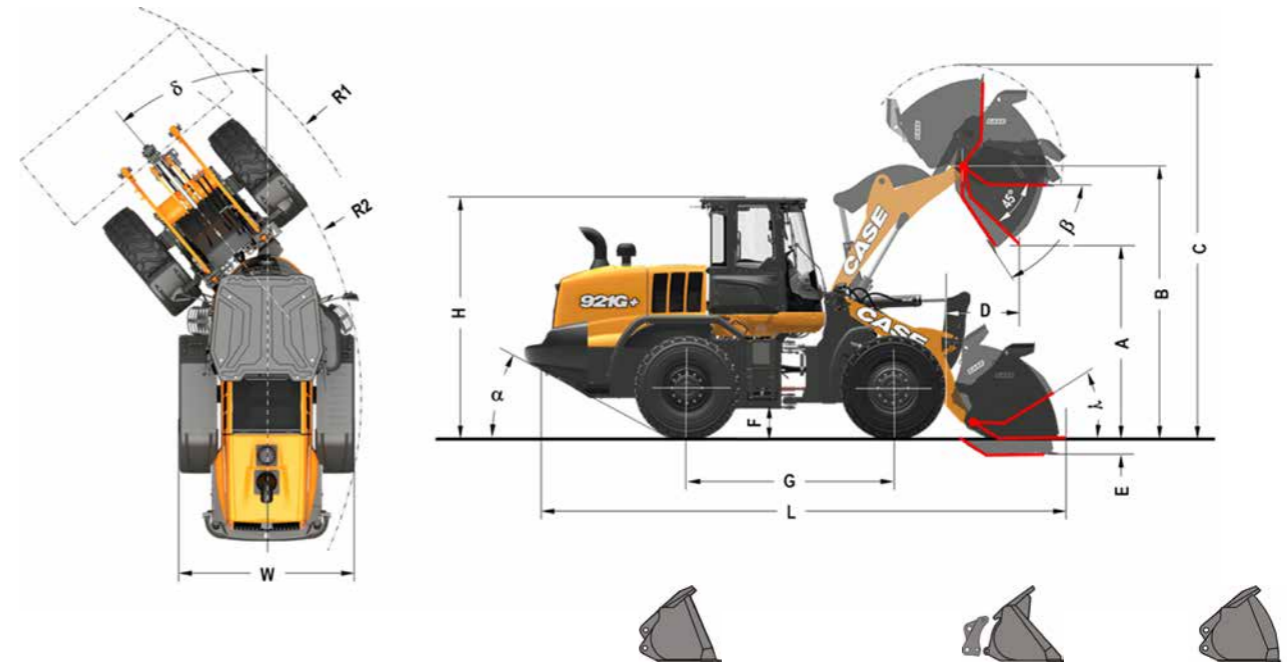

DIMENSION - Data with factory-fitted buckets	G.P. PIN-ON				G.P. QUICK COUPLER				REHANDL.	
	Z-Bar		XR		Z-Bar		XR			
Bucket accessory	B.O.E.	Teeth	B.O.E.	Teeth	B.O.E.	Teeth	B.O.E.	Teeth	B.O.E.	
Bucket Rated Capacity:	m <sup>3</sup>	4	3.8	4	3.8	3.2	3.1	3.2	3.1	4.2
Bucket Capacity at 110% Fill Factor	m <sup>3</sup>	4.4	4.2	4.4	4.2	3.5	3.4	3.5	3.4	4.6
Bucket overall width	mm	2946	2946	2946	2983	2946	2983	2946	2983	3190
Bucket weight	kg	1772	1754	1772	1754	2638	2620	2638	2620	1847
A Dump height at 45° @ full boom height	mm	2949	2862	3440	3358	2809	2722	3298	3213	2903
B Bucket hinge pin height	mm	4200	4200	4647	4647	4200	4200	4645	4645	4200
C Overall height	mm	5810	5810	6256	6256	5673	5673	6118	6118	4200
D Bucket reach, 45° dump @ full boom height	mm	969	1042	1130	1208	1102	1177	1257	1335	986
E Digging depth	mm	44	54	106	116	49	58	111	120	65
F Ground clearance	mm	430	430	430	430	430	430	430	430	430
G Wheel base	mm	3340	3340	3340	3340	3340	3340	3340	3340	3340
H Cab roof height	mm	3460	3460	3460	3460	3460	3460	3460	3460	3460
W Overall vehicle width (without bucket)	mm	2830	2830	2830	2830	2830	2830	2830	2830	2830
L Overall length on ground (with bucket)	mm	8145	8265	8632	8750	8340	8461	8826	8947	8204
α Departure angle	°	29	29	29	29	29	29	29	29	29
R2 Turning radius (at outer wheel)	mm	6030	6030	6030	6030	6030	6030	6030	6030	6030
R1 Turning radius (at bucket corner, max reach)	mm	6624	6676	6873	6873	6684	6739	6946	7006	6745
δ Full steering angle	°	±40	±40	±40	±40	±40	±40	±40	±40	±40
γ Bucket rollback angle @ boom carry position	°	45	45	43	43	44	44	43	43	43
β Bucket dump angle @ maximum boom height	°	48	48	42	42	48	48	43	43	48
<b>LOADER PERFORMANCE</b>										
Bucket accessory	B.O.E.	Teeth	B.O.E.	Teeth	B.O.E.	Teeth	B.O.E.	Teeth	B.O.E.	
Machine operating weight (w/L3 tires)	kg	20425	20407	20689	20671	21291	21274	21555	21537	20501
Tipping load, straight	kg	17720	17395	13774	13900	15372	15446	12248	12306	16605
Tipping load, full turn	kg	14277	14426	11387	11495	12618	12682	9993	10043	13749
Maximum payload	kg	7139	7213	5694	5748	6309	6341	4996	5022	6875
Maximum material density	kg/m <sup>3</sup>	1798	1888	1434	1505	1982	2022	1569	1601	1638
Bucket break-out force	daN	17386	18548	17682	18859	14774	15617	15049	15904	15631
<b>CYCLE TIMES</b>										
Lift (full load)	sec	6.3		6.3		6.3		6.3		6.3
Dump (full load)	sec	1.5		1.5		1.5		1.5		1.5
Lowering (empty, float down)	sec	3.6		3.6		3.6		3.6		3.6

All units equipped with std.\* L3 Radial Tires (Unless Noted), ROPS cab with Heater and A/C, Heavy Counterweight, Front and Rear Fenders, Full Fuel and DEF tanks, 75 kg operator. Specifications per ISO 14397, ISO 5998 AND ISO 7546.

\* STD Tires size per model: 521G: 17.5R25 | 621G-651G-721G: 20.5R25 | 821G-921G: 23.5R25

## LOADER SPECIFICATIONS 521G+ | 621G+ | 651G+ | 721G+ FORKS, Z-BAR & XR

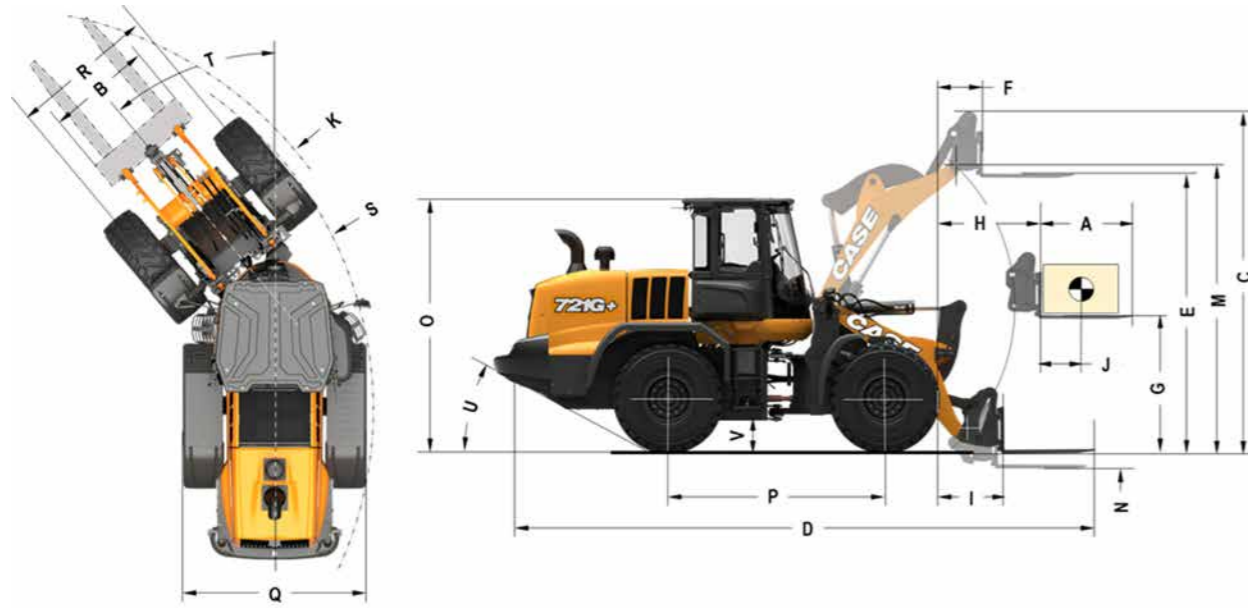

DIMENSION - Factory-fitted forks and quick coupler	521G+		621G+		651G+		721G+	
	Z-Bar	XR	Z-Bar	XR	Z-Bar	XR	Z-Bar	XR
A Fork length	mm	1200	1200	1200	1200	1200	1220	1220
B Attachment width	mm	1500	1500	1500	1500	1500	1500	1500
Attachment weight - includes coupler	kg	742	742	801	801	801	1056	1056
C Overall height @ top of attachment, forks level	mm	3766	4146	3925	4350	4033	4458	4577
D Overall length - forks level on ground	mm	7122	7473	7614	8033	7624	8043	8349
E Fork clearance @ full height	mm	3397	3777	3626	4051	3731	4156	3802
F Fork reach @ full height	mm	701	675	578	579	458	431	618
G Fork clearance @ max reach	mm	1667	1666	1755	1755	1751	1751	1762
H Fork reach (max)	mm	1421	1688	1376	1698	1376	1698	1499
I Fork reach @ ground	mm	762	1113	691	1110	701	1120	875
J Fork load center	mm	600	600	600	600	600	600	600
K Turning radius w/ forks in carry position w/ 15° rollback	mm	5359	5567	5531	5776	5531	5776	6058
M Hinge pin height - full height	mm	3605	3985	3833	4258	3938	4363	4080
N Dig depth	mm	32	67	12	17	(-)	(-)	42
Common dimensions for all machines equipped with same tires:								
O Overall height - top of cab	mm	3275	3275	3384	3384	3384	3381	3377
P Wheelbase	mm	2750	2750	2900	2900	2900	2900	3253
Q Overall width - w/o attachment	mm	2448	2448	2478	2478	2478	2478	2558
R Tread width	mm	2000	2000	1950	1950	1950	1950	2030
S Turning radius	mm	5002	5002	5223	5223	5233	5233	5748
T Turning angle from center	°	±40	±40	±40	±40	±40	±40	±40
U Departure angle	°	30	30	25	25	25	25	29
V Ground clearance	mm	341	341	389	389	389	389	384
<b>OPERATIONAL DATA</b>								
Operating weight (without load)	kg	10933	11121	12754	12936	13939	14121	15477
Operating load:								
50% of full turn tipping load, SAE J1197	kg	2681	2369	3281	2838	3648	3170	3952
60% of full turn tipping load, rough terrain, EN474-3	kg	3217	2842	3937	3405	4377	3804	4743
80% of full turn tipping load, firm & level ground, EN474-3	kg	4289	3790	5249	4540	5836	5072	6324
Tipping load:								
Machine straight	kg	6247	5541	7734	6717	8635	7529	9542
Full turn (40°)	kg	5361	4737	6562	5675	7296	6340	7904

All units equipped with std.\* L3 Radial Tires (Unless Noted), ROPS cab with Heater and A/C, Heavy Counterweight, Front and Rear Fenders, Full Fuel and DEF tanks, 75 kg operator. Specifications per ISO 14397, ISO 5998 AND ISO 7546.

\* STD Tires size per model: 521G: 17.5R25 | 621G-651G-721G: 20.5R25 | 821G-921G: 23.5R25

## LOADER SPECIFICATIONS 821G+ | 921G+ FORKS, Z-BAR & XR

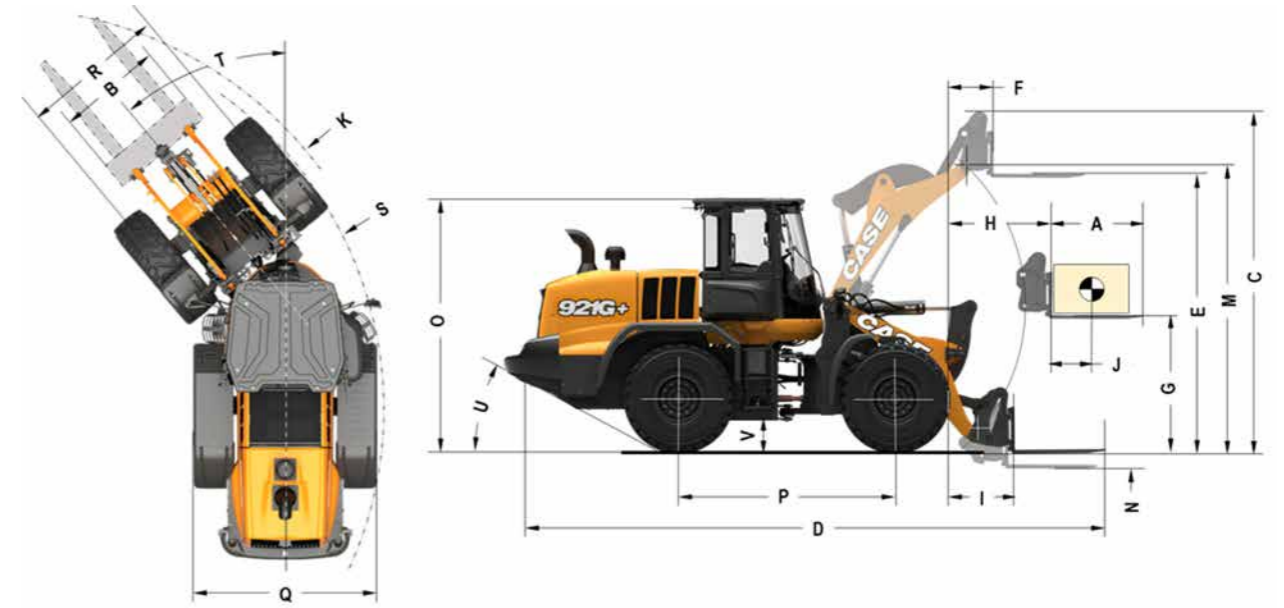

DIMENSION - Factory-fitted forks and quick coupler	821G+		921G+	
	Z-Bar	XR	Z-Bar	XR
A Fork length	mm	1250	1250	1250
B Attachment width	mm	1500	1500	1500
Attachment weight - includes coupler	kg	1257	1257	1257
C Overall height - operating top of attachment, forks level	mm	4203	4644	4280
D Overall length - forks level on ground	mm	8244	8720	8346
E Fork clearance @ full height - ground to top of tine	mm	3917	4358	3999
F Fork reach @ full height - vertical front surface of tine to front of tire	mm	680	793	599
G Fork clearance @ max reach - ground to top of tine	mm	1850	1850	1855
H Fork reach (max) - vertical front surface of tine to front of tire	mm	1542	1944	1542
I Fork reach @ ground - vertical front surface of tine to front of tire	mm	902	1378	921
J Fork load center - vertical front surface of tine to load CG	mm	625	625	625
K Turning radius w/ forks in carry position w/ 15° rollback	mm	6202	6489	6202
M Hinge pin height - full height	mm	4120	4561	4202
N Dig depth	mm	(-31)	36	(-59)
Common dimensions for all machines equipped with same tires:				
O Overall height - top of cab	mm	3460	3460	3465
P Wheelbase	mm	3340	3340	3340
Q Overall width - exclusive of the attachment	mm	2829	2829	2829
R Tread width	mm	2230	2230	2230
S Turning radius	mm	6003	6003	6003
T Turning angle from center	°	±40	±40	±40
U Departure angle	°	29	29	29
V Ground clearance	mm	390	390	390
<b>OPERATIONAL DATA</b>				
Operating weight (without load)	kg	18017	18285	19911
Operating load:				
50% of full turn tipping load, SAE J1197	kg	4484	3774	5144
60% of full turn tipping load, rough terrain, EN474-3	kg	5381	4529	6173
80% of full turn tipping load, firm & level ground, EN474-3	kg	7175	6038	8230
Tipping load:				
Machine straight	kg	10737	9085	12427
Full turn (40°)	kg	8969	7548	10288

All units equipped with std.\* L3 Radial Tires (Unless Noted), ROPS cab with Heater and A/C, Heavy Counterweight, Front and Rear Fenders, Full Fuel and DEF tanks, 75 kg operator. Specifications per ISO 14397, ISO 5998 AND ISO 7546.

\* STD Tires size per model: 521G: 17.5R25 | 621G-651G-721G: 20.5R25 | 821G-921G: 23.5R25

# LOADER SPECIFICATIONS 521G+ | 621G+ | 651G+ | 721G+ BUCKETS, XT

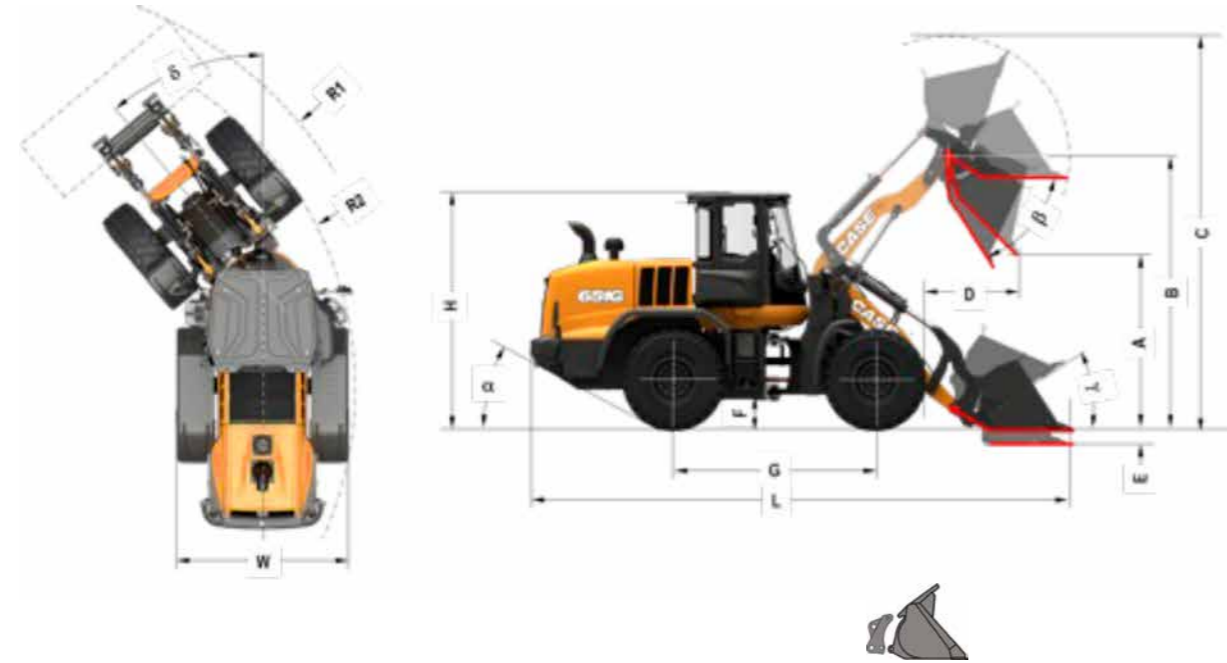

DIMENSION - Data with factory-fitted buckets		521G+		621G+		651G+		721G+	
		XT		XT		XT		XT	
Bucket accessory		B.O.E.	Teeth	B.O.E.	Teeth	B.O.E.	Teeth	B.O.E.	Teeth
Bucket Rated Capacity:	m <sup>3</sup>	1.8	1.7	2	1.9	2	1.9	2.7	2.6
Bucket Capacity at 110% Fill Factor	m <sup>3</sup>	2	1.9	2.2	2.1	2.2	2.1	3	2.8
Bucket overall width	mm	2497	2540	2497	2540	2497	2540	2712	2726
Bucket weight	kg	1050	902	1256	1202	1256	1202	1682	1663
A Dump height at 45° @ full boom height	mm	2428	2357	2572	2495	2569	2492	2796	2689
B Bucket hinge pin height	mm	3743	3743	3960	3960	3956	3956	4154	4154
C Overall height	mm	4932	4932	5233	5233	5230	5230	5504	5504
D Bucket reach, 45° dump @ full boom height	mm	1116	1182	1105	1175	1105	1175	1162	1249
E Digging depth	mm	197	200	180	184	183	188	123	137
F Ground clearance	mm	341	341	389	389	389	389	437	437
G Wheel base	mm	2750	2750	2900	2900	2900	2900	3550	3550
H Cab roof height	mm	3275	3275	3384	3384	3384	3384	3577	3577
W Overall vehicle width (without bucket)	mm	2448	2448	2478	2478	2478	2478	2978	2978
L Overall length on ground (with bucket)	mm	7120	7219	7777	7885	7780	7888	7998	8146
α Departure angle	°	30	30	25	25	25	25	29	29
R2 Turning radius (at outer wheel)	mm	5002	5002	5223	5223	5223	5223	5748	5748
R1 Turning radius (at bucket corner, max reach)	mm	5527	5572	5725	5768	5725	5768	6396	6446
δ Full steering angle	°	±40	±40	±40	±40	±40	±40	±40	±40
γ Bucket rollback angle @ boom carry position	°	53	53	59	59	59	59	47	47
β Bucket dump angle @ maximum boom height	°	57	57	50	50	50	50	61	61
<b>LOADER PERFORMANCE</b>									
Bucket accessory		B.O.E.	Teeth	B.O.E.	Teeth	B.O.E.	Teeth	B.O.E.	Teeth
Machine operating weight (w/L3 tires)	kg	11564	11511	13376	13323	14446	14393	15911	15892
Tipping load, straight	kg	7161	7295	8826	8968	9740	9889	10446	10556
Tipping load, full turn	kg	6235	6360	7613	7744	8467	8606	8679	8774
Maximum payload	kg	3118	3180	3806	3872	4234	4303	4340	4387
Maximum material density	kg/m <sup>3</sup>	1784	1914	1875	2000	2086	2222	1602	1684
Bucket break-out force	daN	7899	8540	10242	10944	10242	10945	11718	12464
<b>CYCLE TIMES</b>									
Lift (full load)	sec	5.4		6.5		n.a.		5.2	
Dump (full load)	sec	2.4		2.4		n.a.		1.3	
Lowering (empty, float down)	sec	3.9		4.2		n.a.		2.4	

All units equipped with std.\* L3 Radial Tires (Unless Noted), ROPS cab with Heater and A/C, Heavy Counterweight, Front and Rear Fenders, Full Fuel and DEF tanks, 75 kg operator. Specifications per ISO 14397, ISO 5998 AND ISO 7546.

\* STD Tires size per model: 521G: 17.5R25 | 621G-651G-721G: 20.5R25 | 821G-921G: 23.5R25

# LOADER SPECIFICATIONS 521G+ | 621G+ | 651G+ | 721G+ FORKS, XT

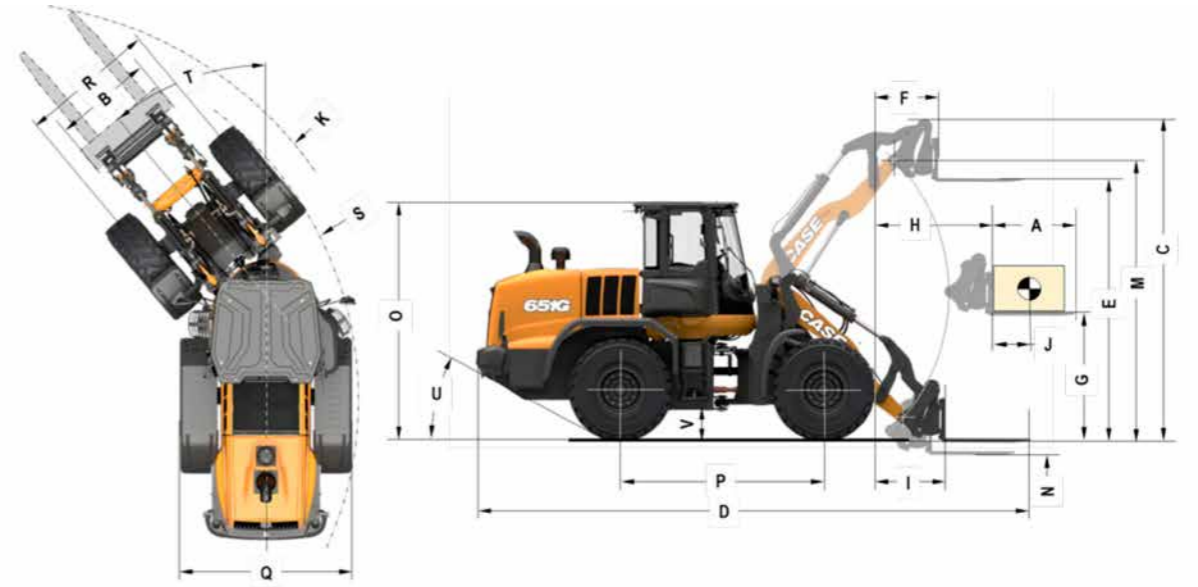

DIMENSION - Factory-fitted forks and quick coupler		521G+		621G+		651G+		721G+	
		XT		XT		XT		XT	
A Fork length	mm	1220	1220	1200	1200	1200	1200	1220	1220
B Attachment width	mm	1500	1500	1500	1500	1500	1500	1500	1500
Attachment weight - includes coupler	kg	704	732	732	732	732	705	705	705
C Overall height @ top of attachment, forks level	mm	3702	3822	3822	3822	3822	4052	4052	4052
D Overall length - forks level on ground	mm	7380	7921	7294	7294	7294	8172	8172	8172
E Fork clearance @ full height	mm	3468	3710	3707	3707	3707	3895	3895	3895
F Fork reach @ full height	mm	958	880	880	880	880	924	924	924
G Fork clearance @ max reach	mm	1712	1806	1803	1803	1803	1855	1855	1855
H Fork reach (max)	mm	1693	1705	1705	1705	1705	1755	1755	1755
I Fork reach @ ground	mm	1000	978	981	981	981	1057	1057	1057
J Fork load center	mm	600	600	600	600	600	609	609	609
K Turning radius w/ forks in carry position w/ 15° rollback	mm	5511	5709	5709	5709	5709	6156	6156	6156
M Hinge pin height - full height	mm	3743	3960	3958	3958	3958	4157	4157	4157
N Dig depth	mm	88	48	51	51	51	12	12	12
Common dimensions for all machines equipped with same tires:									
O Overall height - top of cab	mm	3460	3384	3384	3384	3384	3377	3377	3377
P Wheelbase	mm	2750	2900	2900	2900	2900	3253	3253	3253
Q Overall width - w/o attachment	mm	2829	2478	2478	2478	2478	2558	2558	2558
R Tread width	mm	2230	1950	1950	1950	1950	2030	2030	2030
S Turning radius	mm	6003	5223	5223	5223	5223	5748	5748	5748
T Turning angle from center	°	±40	±40	±40	±40	±40	±40	±40	±40
U Departure angle	°	29	25	25	25	25	29	29	29
V Ground clearance	mm	390	389	389	389	389	384	384	384
<b>OPERATIONAL DATA</b>									
Operating weight (without load)	kg	11218	12853	13922	13922	13922	14934	14934	14934
Operating load:									
50% of full turn tipping load, SAE J1197	kg	2433	2939	3252	3252	3252	3637	3637	3637
60% of full turn tipping load, rough terrain, EN474-3	kg	2920	3527	3903	3903	3903	4365	4365	4365
80% of full turn tipping load, firm & level ground, EN474-3	kg	3893	4703	5204	5204	5204	5820	5820	5820
Tipping load:									
Machine straight	kg	5677	6922	7606	7606	7606	8740	8740	8740
Full turn (40°)	kg	4866	5878	6505	6505	6505	7274	7274	7274

All units equipped with std.\* L3 Radial Tires (Unless Noted), ROPS cab with Heater and A/C, Heavy Counterweight, Front and Rear Fenders, Full Fuel and DEF tanks, 75 kg operator. Specifications per ISO 14397, ISO 5998 AND ISO 7546.

\* STD Tires size per model: 521G: 17.5R25 | 621G-651G-721G: 20.5R25 | 821G-921G: 23.5R25





# BUILDING ON OUR HERITAGE.

Since 1842, at CASE Construction Equipment we have lived by an unwavering commitment to build practical, intuitive solutions that deliver both efficiency and productivity.

The vast CASE dealers' network is always ready to support and protect your investment.

At the end of the day, we do what's right for our customers and our communities so that they can count on CASE.

**CNH Industrial**  
Deutschland GmbH  
Case Baumaschinen  
Benzstr. 1-3 - D-74076 - Heilbronn  
DEUTSCHLAND

**CNH Industrial**  
Maquinaria Spain, S.A.  
Avenida Aragón 402  
28022 Madrid  
ESPAÑA

**CNH Industrial France, S.A.**  
16-18 Rue des Rochettes  
91150 Morigny-Champigny  
FRANCE

**CNH Industrial Italia Spa**  
Lungo Stura Lazio 19  
10156, Torino  
ITALIA

**CASE Construction Equipment**  
Cranes Farm Rd  
Basildon - SS14 3AD  
UNITED KINGDOM

NOTE: Standard and optional fittings can vary according to the demands and specific regulations of each country. The illustrations may include optional rather than standard fittings - consult your Case dealer. Furthermore, CNH Industrial reserves the right to modify machine specifications without incurring any obligation relating to such changes.

Conforms to directive 2006/42/EC

**CASECE.COM**  
**00800-2273-7373**

The call is free from a land line.  
Check in advance with your Mobile Operator if you will be charged. Toll free number not available from all calling areas.